

## **EDITORIAL BOARD**

### **Advisory Editor**

**Andu Dukpa (PhD)**, President, Jigme Namgyel Engineering College, Royal University of Bhutan

### **Editors**

**Hemlal Bhattarai**, Dean Research and Industrial Linkages, Jigme Namgyel Engineering College, Royal University of Bhutan

**Namgay Dorji**, Head, Department of Humanities and Management, Jigme Namgyel Engineering College, Royal University of Bhutan

**Parashuram Sharma**, Assistant Professor, Department of Electrical Engineering, Jigme Namgyel Engineering College, Royal University of Bhutan

**Lobzang Dorji**, Lecturer, Department of Civil Engineering and Surveying, Jigme Namgyel Engineering College, Royal University of Bhutan

**Bikram Chhetri**, Head, Department of Electrical Engineering, Jigme Namgyel Engineering College, Royal University of Bhutan

**Norbu Tshering**, Assistant Professor, Department of Mechanical Engineering, Jigme Namgyel Engineering College, Royal University of Bhutan

### **Production Unit**

**Hemlal Bhattarai**, Dean Research and Industrial Linkages, Jigme Namgyel Engineering College, Royal University of Bhutan

**Editorial Correspondence:** Any inquiries related to Thru-rig Sar-toed, should be addressed to Namgay Zangmo, Asst. Research Officer at [namgayzangmo@jnec.edu.bt](mailto:namgayzangmo@jnec.edu.bt) or Hemlal Bhattarai at [hemlal.jnec@rub.edu.bt](mailto:hemlal.jnec@rub.edu.bt)

**Design and Layout:** Sonam Jamtsho, Head, ITSU, Jigme Namgyel Engineering College, Royal University of Bhutan

---

Copyright © 2019 Jigme Namgyel Engineering College (JNEC), Royal University of Bhutan. All rights reserved. No part of this publication may be reproduced, stored, transmitted, or disseminated, in any form, or by any means, without prior written permission from JNEC, to whom all requests to reproduce copyright material should be directed, in writing.

## Foreword

I am delighted to write the foreword for the Volume II of the “Thru Rig Sar Toed - academic excellence through research and innovation”, a publication of Jigme Namgyel Engineering College (JNEC), where selected scholarly works of students and academics are published. Thru-rig Sar-toed is a humble intent to showcase the scholarly works carried out by students and academics in their respective areas of expertise.

The inaugural volume of the Thru-rig Sar-toed has been well received and I would like to thank our esteemed readers for your support. Every great thing has a humble beginning, likewise, Jigme Namgyel Engineering College is an academic institution that truly believes in taking baby-steps to be able to finally run and achieve greater heights. The first volume of the publication has given us adequate experience and it is our hope that the second volume will help our researchers gain additional experience and enable them to carry out meaningful research works that have deeper impact on the society. In addition, we hope that our esteemed readers are able to connect better with the papers.

Education that we receive will have no meaning if we are not able to bring about positive changes to the society and the mankind. We must provide education to help the mankind and not to destroy it. Therefore, all research works carried out in the academic institutions must be targeted towards eventually bringing benefits to the society. The second volume features seven papers selected from the 2nd Annual Inter-programme Conference held in Jigme Namgyel Engineering College in 2018.

I would humbly request all readers to continue to support us and provide constructive criticism and feedback to enable us to grow further and contribute towards meaningful research and innovation in the area of applied engineering, technology and management.

I would like to congratulate all researchers for your hard work and contribution and continue to hope that we are able to make humble impacts to the society through this publication.

Tashi Delek!

**Andu Dukpa, PhD**

**(President, JNEC)**

## CONTENTS

Sl. No	Topic	Page No.
1	Study on Adaptation of Sustainable Urban Drainage System (SUDS) to Urban Discharge in Samdrup Jongkhar Town, Samdrup Jongkhar: Bhutan	1
2	Site Suitability Analysis for Sustainable Town Planning in Dewathang Using GIS	12
3	Alarm Fencing and Light footpath sensor	21
4	Automatic Green Board Duster	24
5	Smart Metering	27
6	Effect of Inventory Management on The Profitability of Two Manufacturing Companies – A Case Study	34
7	Publicizing on RUB Online Admission	40

# Study on Adaptation of Sustainable Urban Drainage System (SUDS) to Urban Discharge in Samdrup Jongkhar Town, Samdrup Jongkhar: Bhutan

Tashi Tobgay<sup>1</sup>, Nima Tshering<sup>2</sup>, Prakash Laabar<sup>3</sup>, Dhan Kumar Mongar<sup>4</sup>, Tshering Yangchen<sup>5</sup>, Phurba Tamang<sup>6</sup>

Department of Civil Engineering and Surveying, Jigme Namgyel Engineering College  
Royal University of Bhutan, Dewathang, Bhutan

Email: [gawatobgay@gmail.com](mailto:gawatobgay@gmail.com)<sup>1</sup>, [Decembergift2016@gmail.com](mailto:Decembergift2016@gmail.com)<sup>2</sup>, [prakashthegreat16@gmail.com](mailto:prakashthegreat16@gmail.com)<sup>3</sup>,  
[kumardhan627@gmail.com](mailto:kumardhan627@gmail.com)<sup>4</sup>, [yangchentshering206@gmail.com](mailto:yangchentshering206@gmail.com)<sup>5</sup>, [phurbatamang.jnec@rub.edu.bt](mailto:phurbatamang.jnec@rub.edu.bt)<sup>6</sup>

**Abstract—** Increasing urbanization has caused problems with increased flash flooding after sudden rain. As areas of vegetation are replaced by concrete, asphalt or roofed structures, leading to impervious surfaces, the area loses its ability to absorb rainwater. This water is instead directed into surface water drainage systems, often overloading them and causing floods. SUDS replicates the drainage patterns of natural systems by using cost effective solutions with low environmental impact to drain away dirty and surface water run-off through collection, storage and cleaning before releasing back into the environment. This research incorporates a case study in Samdrup Jongkhar town as the area generates massive urban discharge that leads to contamination of adjoining water courses. The paradigm of SUDS solutions should be that of a system that is easy to manage, requiring little or no energy input, resilient to use and being environmentally attractive. Based on the feasibility study several SUDS approaches are recommended for the town. Approaches such as rain gardening, rainwater harvesting, sand filters and parks, etc are suggested to make use of rainwater, to attenuate pressure on existing water supply and to reduce contamination of watercourses.

**Keywords—** Sustainable Urban Drainage System, Rainwater, Rainwater Harvesting, Rain Gardening, Sand Filters

## 1. INTRODUCTION

Drainage is an essential component in urban planning, as it manages proper discharge of rain and wastewaters from the town and disposes away from the settlement. Improper management of drainage systems can lead to over flow in towns and cities subsequently affecting the overall health of adjoining

water courses and deteriorating the aesthetic view of the area. In Bhutan, conventional drainage systems are majorly adopted which fails to function during peak rainy seasons leading to overflow and at times leads to genesis of pavement distresses. Urban discharges tend to even pollute adjoining water courses and can contribute to flash flooding if the factors for drainage designs are compromised by the planners. In Bhutan, urban discharges were found to contaminate the adjoining water courses. In Thimphu, the Wangchu river that runs through Thimphu city, Bhutan's biggest and fastest growing urban center, is more polluted as it passes through the main town and flows downstream as per the report of National Environment Commission. The drain stream that runs from the middle of the city, passing the public toilet and flows into the Wangchu near the vegetable market has an average total nitrogen content of about 13 mg/l (milligrams per liter) and about 1.35 mg/l of total phosphorus. SUDS are an alternative way of urban drainage to collect, clean and release storm water slowly in the environment in natural manner. They are designed to minimize surface runoff and urban flooding which might increase the volume of adjoining water courses. Additionally, it incorporates range of draining techniques which includes filter and infiltration trenches, permeable surfaces, water storage, water harvesting, ponds, etc. It is a new understanding of storm water as a resource rather than that as a waste product, nuisance or hazard. In this approach, attempts are made for the feasibility check on implementation of any of the SUDS techniques or its integration with the existing drainage system of Samdrup Jongkhar town.

## 2. LITERTATURE REVIEW

Steven J. Burain describes the necessity of proper and efficient drainage system. It also compares the drainage system of the past and the present, which without any doubt points to the fact

that for a healthy environment especially in the areas where the proper design and planning of the drainage systems are inevitable.

Duration Frequency (SDR-IDF) Equation for Sylhet City in Bangladesh, describes the rainfall as a triggering factor for road slope failure. Moreover, study of rainfall and its measure is important as to understand the causes of the failure, the absence of hourly or short time period rainfall in the region is hindrance to similar cases of study. This study makes an attempt to calculate the short time period rainfall.

Saleh A.Al Hassoun developed an empirical formula to estimate design rainfall intensity based on intensity duration frequency( IDF) curves. These curves have been generated from a 32 year recorded rainfall data for Riyadh region. Rainfall intensity -duration-frequency curves describe rainfall intensity as a function of duration for a given return periods which are important for the design of storm water drainage system and hydraulic structures specifically for the rational methods.

Theodore G. Cleveland describes the use of rational method in general for the institution community areas. It also describes the applicable area of rational method. M. M. Rashid, S.B. Faruque and J.B. Alan in modelling of short duration rainfall intensity.

## 3. METHODOLOGY

### 3.1 Study Area

The study area is in Samdrup Jongkhar town, which is located at south east part of Bhutan with an altitude ranging from 200 m to 900 m above the sea level. The town shares a border with Darranga, the Assam state of India. The study area is divided into three zones as shown in Figure. 1. Zone I comprises the premises within the main town area. Zone II is the residential area of National Housing Development Corporation Limited along Dungsam river. Similarly, Zone III incorporates the Dzong area including the SMSS (Samdrup Jongkhar Middle Secondary School) and hospital area. Due to improper urban planning scheme, the drains in these areas have clogged and lacks maintenance at several locations.

### 3.2 Preliminary survey

The preliminary survey for this research covers the following procedures.

- Visual inspection and identification of problems with existing drainage system.
- Dividing the study area based on the frequency and intensity of drainage issues into respective zones.
- Identifying sources of urban discharges apart from rainwater to evaluate possible risk of



Figure 1: Study Area (Samdrup Jongkhar Town)



Dungsam river contamination.

- Identification of areas for establishment of sampling stations in respective zones for feasibility check on implementation of SUDS techniques.

Major issues pertinent to existing drainage system are identified as follows:

**Improper maintenance of drains**

Most of the existing drains found in town were clogged with bushes, soil and plastic wastes which offered hindrances in water movements. These often leads to over flooding during monsoon period.

**Poor drainage along the pavements**

Most locations, lack proper drainage system for run off from the roads. Additionally, the existing drains are poorly maintained. As the town expects heavy rainfall, there is no proper disposal of water leading to stagnation of water on the road. Consequently, frequent stagnation results in pavement deterioration over time.

**Direct disposal of household wastewater into the river**

Due to the lack of proper disposal site for the wastewater, the surface runoff from existing drains get mixed with the wastewaters from household which in turn increases the pollution load in the adjoining river. Residents of the town often depend on this river when there are water chaos in the town especially during monsoon season.

**3.3 Secondary Data Survey**

**3.3.1 Rainfall Intensity**

Rainfall intensity is related to rainfall duration and design storm recurrence interval. For this study, twenty four hours rainfall data for return period of 10 years was collected from Hydro-met station located at Dewathang. The intensity for 10 years of return period is represented in Table. 1.

**3.3.2 Determination of runoff Discharge**

One of the most commonly used procedures for calculating peak flows from small drainage less than 200 acres is the rational method. This method is most accurate for runoff estimates from small drainages with large amount of impervious area. The

Rational Method is the simplest method to determine peak discharge from drainage basin and the run off discharge is calculated using the following equation.

$$Q = CiA.....(i)$$

Discharges were calculated for drains, parking areas, pavements and roofs. Based on the discharges availed from the rational method for different areas appropriate drains were planned for design with respect to the design discharge.

**4. FEASIBILITY CHECK FOR SUDS**

The feasibility check on the SUDS approaches depends on the choice of techniques that is best suited for the study area. For Samdrup Jongkhar town, the check lists includes a park at several locations to increase rate of infiltration, rain water harvesting and rain gardening to store and use rainwater as an alternate resource, infiltration trenches to reduce run off from pavements and footpaths and finally rapid sand filters to attenuate pollution rate of adjoining rivers. The following are the phases that completes the feasibility check of SUDS.

Table 1: Rainfall Intensity for Return Period

Sl. No	Return Periods	Rainfall Intensity (mm/day)	Rainfall Intensity (mm/hr)
1	1	156	6.52
2	2	171	7.12
3	3	185	7.72
4	4	200	8.32
5	5	214	8.92
6	6	228	9.51
7	7	243	10.11
8	8	257	10.71
9	9	271	11.31
10	10	286	11.91

**4.1 Laboratory Test**

**4.1.1 Grain-size distribution**

This test determines the particle size distribution of soil from the coarse sand size down to fine silt and clay size. The data for particle size distribution test is used to determine suitability of soil for its permeability criteria. Sandy soils are generally

preferred for its permeability and subsequently can be used for planning detention ponds to ensure filtration of wastewater naturally into the sub soil strata. The soils were tested for permeability along the main drains where it adjoins the main river.

**4.1.2 Water Quality Assessment of Dungsam River**

The water samples before and after the outfall were collected to assess the water quality. The assessed water parameters were studied and analyzed to choose preferable filtration approaches to reduce water pollution. The water samples were tested for pH, turbidity, dissolved oxygen and total dissolved solids.

**4.2 Data Representation**

The data obtained from test performed on soil and water samples are represented on Figure. 2 and Table. 2 These values will be later utilized to make essential inferences .

**4.3 Design of Drainage System**

Based on discharges obtained from respective drains and the main drains, the existing drainage systems within the vicinity of the town were re-designed. The designed drainage systems can help in reducing the runoff during monsoon and

will have less clogging as every designs have self cleaning attributes. The details of both rectangular and trapezoidal drains are furnished in Table. 3 and Table. 4

**5. RESULT**

Referring to soil and water test data it can be inferred that all the zones do not have a properly graded sandy soil which is not feasible for planning of detention ponds rather, a filtration unit is essential to improve water quality of urban discharges. Therefore, a rapid sand filter is proposed to mitigate water pollution at main outfalls. The following conclusions were also drawn.

Frequent maintenance of existing drains need to be carried out to prevent clogging and overflows.

The existing main drains in the town were sustainable for future years but the sub drains causes prevent over flooding.

The effluent from main drains were found to contaminate Dungsam river whereby the effluent needs treatment before disposal.

Drains along the road should be properly maintained and should be kept free from growth of bushes.

Suitable SUDS techniques should be

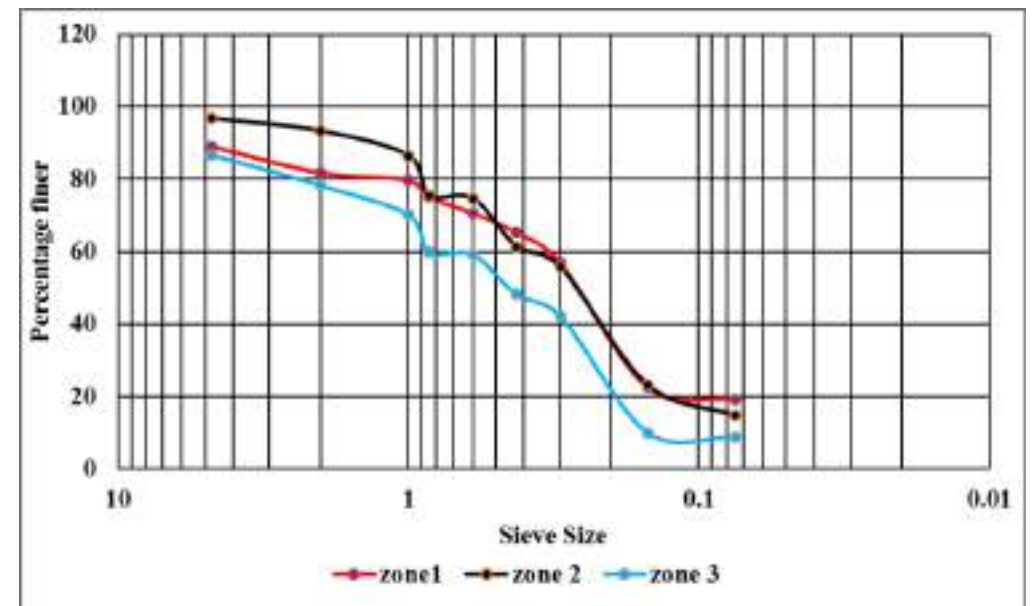

Figure 2: Grain Size Distribution Curve for study zones

Table 2: Data representation of water quality assessment

Zone	Sampling point	Parameters	Unit	Permissible Limits	Result
Zone I	Water Above the Outfall	Temperature	Degree Celsius	5-25	23.09
		pH	pH	6.5-8.5	4.3
		Turbidity	NTU	10-25	269
		Dissolved Oxygen	mg/l	4-5	0.18
		Total dissolved Solid	mg/l	300-500	0.439
	Water Below the Outfall	Temperature	Degree Celsius	5-25	22.88
		pH	pH	6.5-8.5	5.47
		Turbidity	NTU	10-25	178.5
		Dissolved Oxygen	Mg/l	4-5	0.17
		Total dissolved Solid	g/l	300-500	0.84
Zone II	Water Above the Outfall	Temperature	Degree Celsius	5-25	22.96
		pH	pH	6.5-8.5	4.97
		Turbidity	NTU	Oct-25	234
		Dissolved Oxygen	Mg/l	4-5	0.16
		Total dissolved Solid	g/l	300-500	0.825
	Water Below the Outfall	Temperature	Degree Celsius	5-25	22.67
		pH	pH	6.5-8.5	6.24
		Turbidity	NTU	10-25	238.4
		Dissolved Oxygen	Mg/l	4-5	0.35
		Total dissolved Solid	g/l	300-500	1.08

Table 3: Design Detains for Rectangular Drain

Designated drain	Discharge	Velocity (m/sec)	Area of drain (A)	Wetted Perimeter (P)	Hydraulic Radius (R )	Top Width (T)	Hydraulic Depth (D)	Slope (S)
D1	1.3578	1.5	0.9	2.69	0.34	1.35	0.81	0.006
D2	3.237	1.5	2.2	4.15	0.52	2.08	1.25	0.003
D3	1.472	1.5	1	2.8	0.35	1.4	0.84	0.005
D4	1.346	1.5	0.9	2.68	0.33	1.34	0.8	0.006
D5	1.371	1.5	0.9	2.7	0.34	1.35	0.81	0.006
D I	3.237	1.5	2.2	4.15	0.52	2.08	1.25	0.003
D3	4.4101	1.5	2.9	4.85	0.61	2.42	1.45	0.003
D4	2.3901	1.5	1.6	3.57	0.45	1.79	1.07	0.004
D5	2.1771	1.5	1.5	3.41	0.43	1.7	1.02	0.004

Table 4: Design Detains for Trapezoidal

Designated drain	Discharge	Velocity (m/sec)	Area of drain (A)	Wetted Perimeter (P)	Hydraulic Radius (R )	Top Width (T)	Hydraulic Depth (D)	Bottom Width (B)	Slope (S)
D1	1.3578	1.5	0.9	2.504	0.361	1.67	1.157	0.603	0.005
D2	3.229	1.5	2.2	3.862	0.557	2.575	1.784	1.435	0.003
D3	1.464	1.5	1	2.6	0.375	1.734	1.201	0.651	0.005
D4	1.338	1.5	0.9	2.486	0.359	1.657	1.148	0.595	0.005
D5	1.363	1.5	0.9	2.509	0.362	1.673	1.159	0.606	0.005
D I	3.229	1.5	2.2	3.862	0.557	2.575	1.784	1.435	0.003
D6	4.4101	1.5	2.9	4.513	0.651	3.009	2.085	1.96	0.002
D7	2.3901	1.5	1.6	3.323	0.48	2.215	1.535	1.062	0.003
D8	2.1771	1.5	1.5	3.171	0.458	2.114	1.465	0.968	0.004



Figure 3: Rain Garden



Figure 4: Water Harvesting

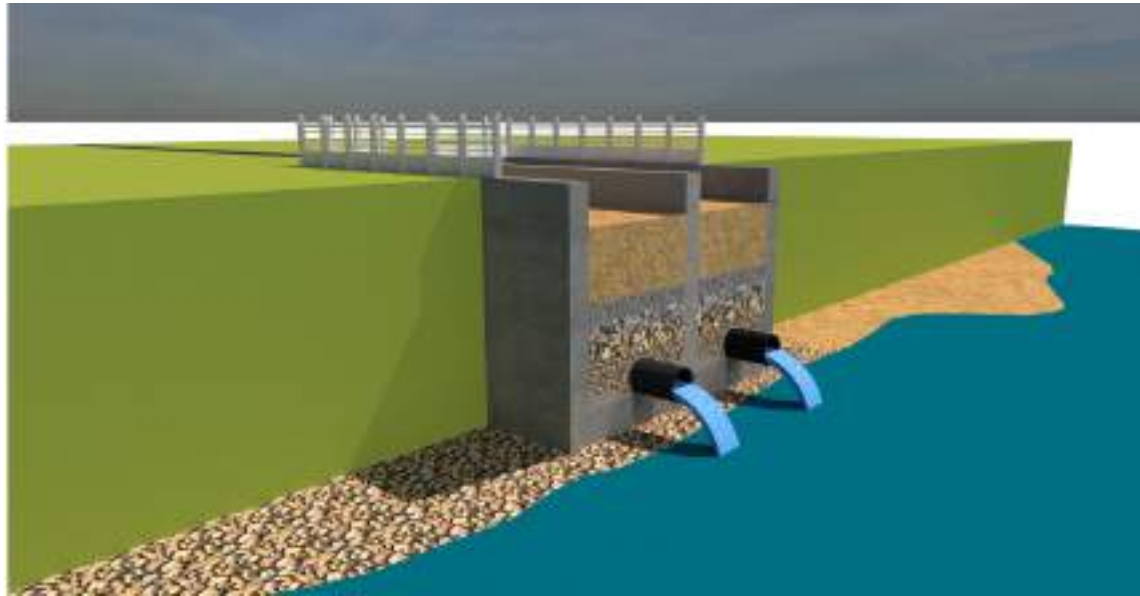

Figure 5: Rapid Sand Filtration Unit for treatment of Urban Discharges



Figure 7: Proposed Park

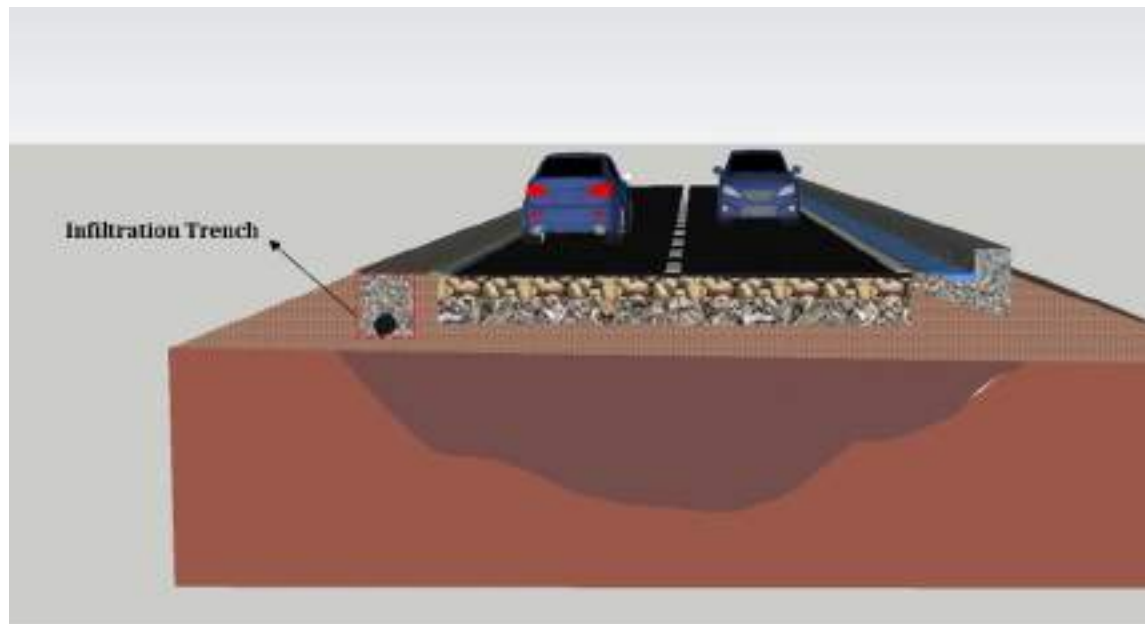

Figure 6: Infiltration Trenches along the roads

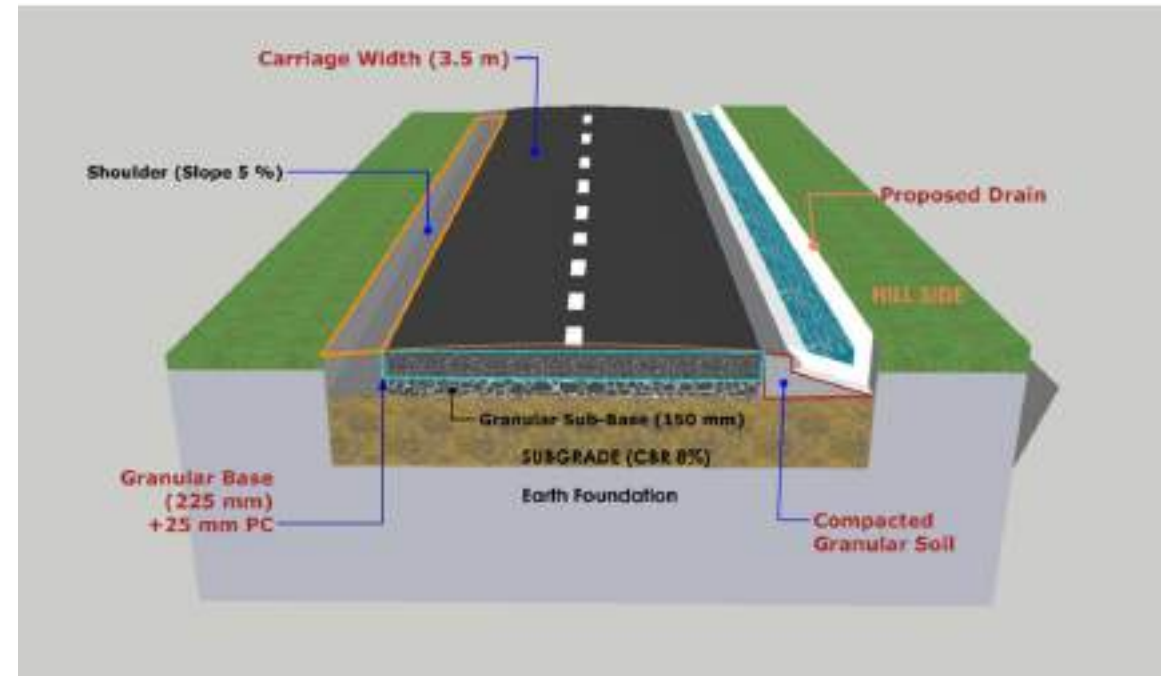

Figure 8: Road for the town





Figure 9: Proposed SUDS for Zone I

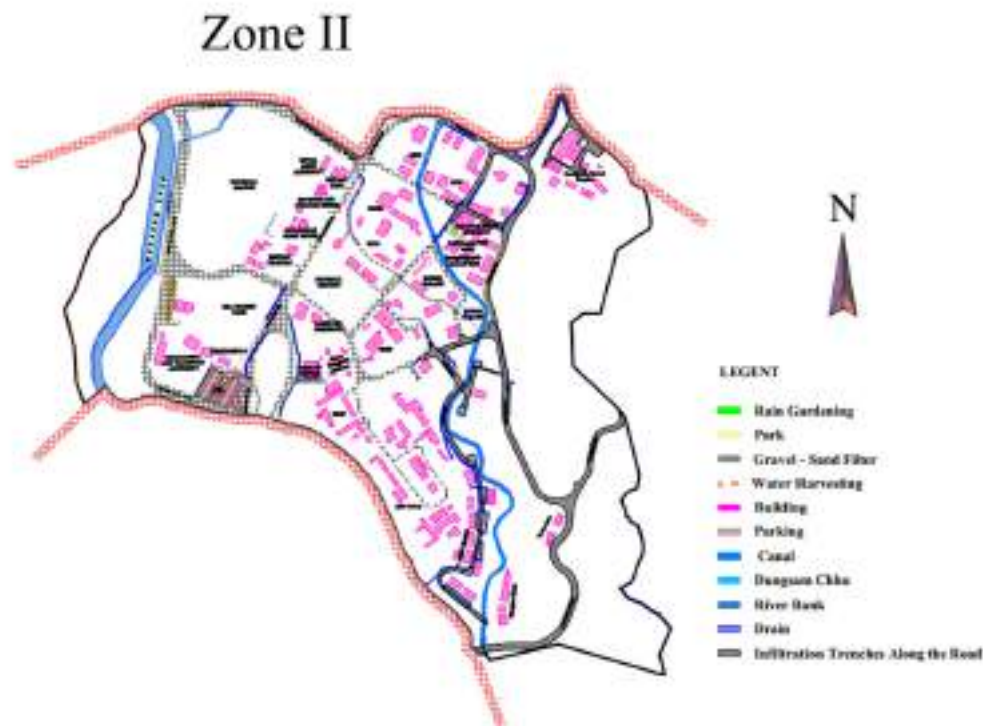

Figure 10: Proposed SUDS for Zone II



Figure 11: Proposed SUDS for Zone III

implemented in respective zones to attenuate issues related to urban discharge.

The proposed SUDS techniques feasible for the town are represented in Figure 3, Figure 4, Figure 5, Figure 6, Figure 7 and Figure 8. They have been represented on the existing map of the town as shown by Figure 9, Figure 10 and Figure 11.

## 6. RECOMMENDATION

The recommendations from this research have been laid out as following.

### 6.1 Recommendations for Planners

Proper road geometry with drainage system should be provided for all roads in Samdrup Jongkhar town.

Drainage layout plan needs to be properly planned before execution.

Implantation of SUDS technique such as rain water harvesting to solve water related issues in the town.

Construction of park and infiltration trenches can help to reduce run offs in respective zones.

Rapid sand filters can be used to treat the effluent before disposal.

### 6.2 Recommendations for future researchers

This research was limited to only urban catchment areas (road, parking and roofs) and provides limited data for future referencing. Future researchers can increase the catchment area and work for data in line with existing data.

## 7. ACKNOWLEDGEMENT

The research team would like to thank Mr. Phurba Tamang, Associate Lecturer in Department of Civil Engineering and Surveying for his unwavering support to complete this research.

## REFERENCES

- [1] Arora, K. R. Irrigation, water power and water resources engineering. Standard Publisher Distributors.
- [2] Getachew K., Tamene W., Demissie A., (2015) Assessment of the effect of urban road surface drainage: A case study at Ginjo Guduru Kebele of Jimma Town. International Journal of Science, Technology and Society. Vol. 3 No. 4, 2015, pp. 164-173.10.11648/j.ijsts.20150304.20
- [3] Gupta, B. L and Gupta, A. Water Resources System and Management. Standard Publishers Distributors.
- [4] Needhidasan. S and Nallnathel M. Design

of storm water management for environmental protection. International Journal of Engineering and Technology (IJET).

[5] Rashid, M.M., Farugue, S.B & Alam, J.B. (2012). Modeling of short Duration Rainfall Intensity Duration Frequency (SDR- IDF) equation for Sylhet city in Bangladesh. ARPN Journal of Science and Technology, 2(2), 93-95.

[6] Saleh A. Alhassonn (22 May 2010). Developing an empirical formulae to estimate

Rainfall Intensity in Riyadh region. Journal of King Saud University- Engineering Sciences.

[7] Warren V. Jr. and Garay L. Lewis. Introduction to Hydrology. Fifth edition, Eastern Economy Edition.

[8] Burlando P. and Rosso R., (1996). Scaling and multi-scaling models of depth duration frequency curves for storm precipitation. Journal of Hydrology . 187(1-2): 45-64.

## Site Suitability Analysis for Sustainable Town Planning in Dewathang Using GIS

Yenten Jamtsho<sup>1</sup>, Provin Rai<sup>2</sup>, Sangay Thinley<sup>3</sup>, Tshering Zam<sup>4</sup>, Samten Norbu<sup>5</sup> and Pema Khandu<sup>6</sup>

Diploma in Surveying, Civil Engineering and Surveying Department, Jigme Namgyel Engineering College, Dewathang, Samdrup Jongkhar, Bhutan

E-mail: yeenteenjamtsho94@gmail.com<sup>1</sup>, prox365@gmail.com<sup>2</sup>, Thinleysangay448@gmail.com<sup>3</sup>, pemakghandu46@gmail.com<sup>4</sup>, samtennorbu456@gmail.com<sup>5</sup>, moonlovereva@gmail.com<sup>6</sup>, tsheringchoki@jnec.edu.bt<sup>7</sup>, sanjitkc93@gmail.com<sup>8</sup>

**Abstract— This project illustrates the use of Geographic Information System (GIS) tools and numerical Multi-Criteria Evaluation (MCE) techniques for selection of suitable sites for urban development in Dewathang. This project was conducted to identify suitable sites for Commercial, Residential, Recreational, Parking, Solid Waste and Protected Forest Area using GIS-based multi-criteria evaluation of slope, road proximity, land use, land values, aspect, altitude, proximity form core town and other such criteria. . Criteria weights and maps were combined using Weighted Overlay Technique to identify and locate most suitable sites for above activity. The results of analysis have shown that there are 65.94 acres suitable for commercial, 137.85 acres suitable for Residential, 18.04 acres suitable for Recreational, 21.10 acres suitable for Parking, 26.30 acres suitable for Waste Disposal and 132.51 acres suitable for Reserved Forest Area within the study area.**

### 1. INTRODUCTION

The suitability analysis for urban growth is considered one of the most important and effective techniques for identifying the best urban growth locations. This technique employs different types of criteria and weights [1]. Land suitability evaluation involves the selection of suitable locations of development via mapping of the suitability index of a specific area [2]. GIS techniques have become a significant tool for controlling and monitoring changes in urban development and their impact on ecosystems [3]. Site suitability analysis based on GIS environments is a process that aims to identify the best locations of development while considering environmental sustainability.

### 2. MATERIALS AND METHODS

#### 2.1 Study Area

The project site Dewathang town is situated in Samdrup Jongkhar Dzongkhag, Eastern Region of Bhutan at an elevation of 744 meters above the mean sea level with a total planning area of 2.53 sq.km. The town is located at a distance of 18 Km along the intermediate highway from Samdrup Jongkhar town, an international border town. Samdrup Jongkhar Thromde (Municipal) area includes the area under the Samdrup Jongkhar town as well as the settlement in Dewathang town [4].

#### 2.2 Data source

Data used in this study were assembled from a variety of sources (Table 1). The primary data that is the 1:25000 topographic map was gathered from Samdrup Jongkhar Thromde. In addition geospatial datasets such as Geo-Eye Satellite Image of 0.5m resolution, ground elevation Model (DEM) with 5m x 5m spatial resolution, were incorporated. Moreover, demographic data was collected from Dewathang Structural Plan to analyze population density per Kebeles using GIS shape files.

All data were projected to DRUKREF\_03\_Samdrup\_Jongkhar projection, Transverse Mercator Zone 45 North.



Table 1: List of data and their original source

Sl. No	Data Type	Data Source
1	Topographic map	Sumdrup Jongkhar Thromde
2	Satellite image (Geo-Eye image Resolution (0.5m))	Department of Mines and Geology
3	DEM file	Converted from Base map (NLCS)
4	Population	Dewathang Structural Plan
5	NLCS ground control points	NLCS
6	Existing and Proposed Road Network	Samdrup Jongkhar Thromde
7	LAP Boundary	Samdrup Jongkhar Thromde

The various data (Table 1) were processed and analyzed using ArcGIS, LisCAD and Google Earth as appropriate. Topographic analysis, parcel analysis, network analysis digitization and classification were some of the analysis performed on the data. Tabular data for population from structural plan was forecasted for 10 years to incorporate in the project.

### 2.3 GIS based AHP

The selection of suitable sites is based upon a specific set of local criteria. Criteria is a general category of information concerning the site being evaluated [5]. The characteristics of a site (e.g., present land use, slopes, water availability, distance from roads, altitude, etc.) influence its suitability for a specific purpose such as Commercial, Residential, Recreational, Parking, Solid waste, and Protected Forest area.

In this project, previous studies and expert opinions were used to identify the significant factors that influence the determination of appropriate sites for specific urban planning use. GIS based site suitability analysis involves geographical representation and classification of appropriate parameters based on their relative importance and suitability score.



Figure 1: Flow Chart for Suitability Analysis for Urban Planning

Table 2: Saaty's 9 point weighing Scale

Description of preference	Scale
Equally	1
Equally to moderately	2
Moderately	3
Moderately to strongly	4
Strongly	5
Strongly to very strongly	6
Very Strongly	7
Very strongly to extremely	8
Extremely	9

To do this, a pairwise comparison matrix using Saaty's nine-level scale (Table 2) for identifying relative weights was used. The calculation of factor weights was applied after the formation of the pairwise comparison matrix.

The next step involves the computation of Consistency Ratio (CR), which is used to verify the reliability of the judgment of the decision maker. The acceptable Consistency Ratio (CR) should be  $CR < 0.10$ , which refers to a reasonable level of consistency in the pairwise comparisons [6]. In contrast,  $CR > 0.10$  refers to ratio values that are indicative of inconsistent judgments.

In AHP, all identified factors are compared against each other in a pair wise comparison matrix which is a measure of relative preference among the factors.

The pairwise AHP calculates the weights values and build the estimation matrix for the influencing factor

### 2.4 Suitability Map

Based on the given priority preferences for every set of criteria under commercial, residential, recreational, parking, solid waste and protected forest area; respective criteria maps were prepared using GIS. These criteria maps were reclassified respectively to develop suitability criterion such as not suitable, less suitable, moderately suitable and highly suitable and then overlaid using Weighted Linear Overlay Method and the influencing weight factor calculated from AHP to obtain a final suitability map.

The Weighted (WLC) was computed using the formula adopted by [6] as

$$S = \left( \sum_{i=1}^n W_i \times X_i \right) \times \prod C_j$$

Where;

S = Suitability map

$\Sigma$  = Sum of weighted factors

n = Number of Criteria

W<sub>i</sub> = Weights of each criteria i

X<sub>i</sub> = Score of the criteria

C<sub>j</sub> = Restriction (Boolean map represented with values of 0 or 1)

$\Pi$  - Product of restriction (1-suitable, 0-unsuitable)

## 3. SITE SUITABILITY FOR TOWN PLANNING

Planning in any town or city is an essential part of growth, development, and sustainability of resource. Proper town planning provide the overall economic stability and growth in a community, public services to meet the general needs of the community and protect the environment [7]. For sustainable town planning, the selection of potential site is critical point for starting, expanding or changing the location of town. The main objectives of site suitability analysis is finding the most appropriate site for a particular activity with desired conditions defined by

the selection criteria.

Site Suitability Analysis for Commercial, Residential, Recreational, Parking, Solid-waste and Protected Forest Area is crucial for a planned urban growth.

### 3.1 Site Auitability Analysis for Commercial Area

Commercial Area are the most glorious places these days with their attractive shops and a wide variety people where people spend their weekends to relax and shopping. The increase in the population will cause a demand for easier and quicker access to food, clothing and home products creating an increase in economic business growth [8]. Effective criteria (factor) used in the identification of suitable sites for commercial area with their individual importance is shown in Table 3 and the weights of their influencing factor for suitability analysis is in Table 4.

Table 3: Summary of Criteria for Commercial Development Area

Criteria Matrix for Commercial Development Area		
Criteria	Sub-Criteria	Weight
Distance from existing Commercial area	0-400m	5
	400-800m	4
	800-1200m	3
	1200-1600m	2
	1600-2000m	1
Distance from Highway	0-200m	5
	200-400m	4
	400-600m	3
	600-800m	2
	800-1000m	1
Slope	0-12%	5
	12-18%	4
	18-23%	3
	23-28%	2
	28-57%	1
Land Use	Buildup Area	6
	Road	5
	Barren Land	4
	Thin vegetation	3
	Dense Area	2
	Cultivated Area	1

Table 4: Influencing Weights of Criteria

Criteria	Weightage (%)
Distance from existing Commercial area	56
Distance from Highway	26
Slope	12
Land Use	6

Criterion maps were prepared for Table 3 in GIS, reclassified and all the criteria maps were overlaid using the influencing weights of Table 3 to produce a site suitability map for commercial area as shown in Fig. 2 in Result.

### 3.2 Site Suitability Analysis for Residential Area

Site suitability for residential area refers to the identification and selection of potential sites for housing development. Since urbanization process and population growth is inevitable, identifying suitable building site for residential development is necessary.

Table 5: Influencing Weights of Criteria

Criteria Matrix for Residential Development Area		
Criteria	Sub-criteria	Value
Slope	0-8%	5
	8-15%	4
	15-20%	3
	20-30%	2
	30-56.78%	1
Distance from Road	0-100m	5
	100-200m	4
	200-300m	3
	300-400m	2
	>400m	1
Distance from Stream	>400m	5
	400-300m	4
	300-200m	3
	200-200m	2
	100-0m	1
Aspect	North	4
	East	3
	West	2
	South	1

Land Use Land Cover	Barren Land	4
	ThinVegettion	3
	ThickVegettion	2
	Built-up Area	1

Table 6: Influencing Weights for Criteria

Criteria	Weightage (%)
Slope	11
Distance from Road	27
Distance from Stream	7
Aspect	4
Land Use Land Cover	51

Effective criteria (factor) used in the identification of suitable sites for residential area with their individual importance is shown in Table 5 and the weights of their influencing factor for suitability analysis is in Table 6.

Criterion maps were prepared for Table 5 in GIS, reclassified and all the criteria maps were overlaid using the influencing weights of Table 6 to produce a site suitability map for residential area as shown in Fig. 3 in result

### 3.3 Site Suitability Analysis for Recreational Area

Recreational areas are the important element for attractive town. Recreation are resources and services provided for the purpose of leisure, entertainment, and recreational pursuits. Recreational activities are often done for enjoyment, amusement or pleasure.

Effective criteria used in identification of suitable sites for recreational area with their individual importance is shown in Table 7 and the weights their influencing factor for suitability analysis is in Table 8

Table 7: Influencing Weights of Criteria

Criteria	Weightage (%)
Land Availability	56
Land Use	26
Distance from Road	12
Slope	6

Table 8: Summary of Criteria for Recreational Development Area

Criteria Matrix for Recreational Development Area		
Criteria	Sub-criteria	Value
Land Availability (sq.m)	105000-116000	5
	35000-105000	4
	15000-35000	3
	8000-15000	2
	0-8000	1
Land Use	Barren land	5
	Thin vegetation	4
	Dense vegetation	3
	Cultivated area	2
	Built-up area	1
Distance from Road	0-100m	4
	100-200m	3
	200-300m	2
	>300m	1
Slope	0-8%	5
	8-15%	4
	15-25%	3
	25-35%	2
	>35%	1

### 3.4 Site Suitability Analysis for Vehicle Parking

A town must have enough parking spaces to provide their resident and their visitors a place to park their car. Parking is one of the important element for healthy and organized town. Parking should be planned to encourage transit use and support commercial activity. Optimum site selection for public parking spaces not only increases the parking efficiency, but also decreases marginal car parking and therefore, results in increase of streets' width and traffic fluency.

Effective criteria (factor) used in the identification of suitable sites for parking area with their individual importance is shown in Table 9 and the weights of their influencing factor for suitability analysis is in Table 10.

Criterion maps were prepared for Table 9 in GIS, reclassified and all the criteria maps were overlaid

using the influencing weights of Table 10 to produce a site suitability map for vehicle parking area as shown in Fig. 5 in results.

Table 9: Influencing Weights for Criteria

Criteria Matrix for vehicle Parking Area		
Criteria	Sub-criteria	Value
Distance to Major Center	100-150m	5
	150-200m	4
	200-250m	3
	250-300m	2
	300-350m	1
Distance from Road	10-50m	5
	50-100m	4
	100-150m	3
	150-200m	2
	200-225m	1
Land use/and Cover	Road	6
	Barren	5
	Thin vegetation	4
	Cultivated area	3
	Thick vegetation	2
	Built-up	1

Table 10: Summary of Criteria for Reserved Forest Area

Parameter	Weightage (%)
Distance to Major Center	63
Distance from Road	26
Land use/Land Cover	11

Solid wastes indiscriminately thrown resulted also in aesthetic problems, nuisance, and pollution of land and water bodies of an area [7]. Therefore, locating proper sites for solid waste disposal and selecting appropriate landfill site far from residential areas, environmental resources and settlement necessary for the management of solid waste.

Table 11: Summary of Criteria for Solid Waste Disposal Area

Criteria Matrix for Solid Disposal Area		
Criteria	Sub-criteria	Value
Slope (in %)	0 – 12	5
	12 – 18	4
	18 – 24	3
	24 – 28	2
	28 – 57	1
Land Use and Cover	Barren Land	5
	Thin Vegetation	4
	Dense Vegetation	3
	Cultivated Land	2
	Road	1
Distance to Road (in meter)	0 – 100	1
	100 - 200	2
	200 - 300	3
	300 - 400	4
	400 - 500	5

Table 12: Influencing Weights for Criteria

Parameter	Weightage (%)
Slope	67
Land use/Land Cover	24
Distance to Road	9

Criterion maps were prepared for Table 11 in GIS, reclassified and all the criteria maps were overlaid using the influencing weights of Table 12 to produce a site suitability map for waste disposal area as shown in Fig. 6 in result.

### 3.5 Site Suitability Analysis for Reserved Forest

A reserved forest is specific terms that are used for designating forests and the natural areas, which enjoy judicial or constitutional protection under the legal system of the countries. Effective criteria (factor) used in the identification of suitable sites for parking area with their individual importance is shown in Table 13 and the weights of their influencing factor for suitability analysis is in Table 14.

Table 13: Influencing Weights for Criteria

Parameter	Weightage (%)
Land use/Land Cover	56
Distance from Main Town	26
Altitude	11
Distance from Road	7

Criterion maps were prepared for Table 13 in GIS, reclassified and all the criteria maps were overlaid using the influencing weights of Table 14 to produce a site suitability map for protected forest area as shown in Fig 7 in result.

Table 14: Influencing Weights for Criteria

Criteria Matrix for Reserved Forest Area		
Criteria	Sub-criteria	Value
Land Use and Cover	Built-up/barren	3
	Thin vegetation	2
	Thick vegetation	1
Distance from Main Town	0-400m	5
	400-800m	4
	800-1200m	3
	1200-1600m	2
	1600-2000m	1
Altitude	400-500m	5
	500-600m	4
	600-700m	3
	700-800m	2
	800-900m	1
Distance from Road	0-200m	5
	200-400m	4
	400-600m	3
	600-800m	2
	800-1000m	1

## 4. FIELD VALIDATION AND FINAL ZONATION

Field validation or field visit is one of the important activity in site suitability analysis using GIS. After determining all the suitable sites in map, field validation is necessary to determine whether the suitable sites got from analysis are feasible in reality or not and to evaluate site already existing in the study area . Satisfactory results were obtained from

field validation. After field validation, the project area was zoned. Zoning is the process of dividing land into zones (eg., commercial, residential, recreational, etc.) in which certain land-uses are permitted or prohibited. Zoning will specify a variety of outright and conditional uses of land and also indicate the size and dimensions of land area as well [9]. The final zoned map of Dewathang, showing the most suitable sites for Commercial, Residential, Recreational, Parking, Solid Waste disposal area and Protected Forest area is shown in Fig.8.

## 5. RESULT AND DISCUSSION

Final suitability maps for Commercial, Residential, Recreational, Parking, Solid Waste Disposal Area and Protected Area were extracted using weighted overlay techniques in ArcGIS 10.3. The feasibility of suitable sites determined for the above purposes were validated by field visit and then zoned to locate the most suitable sites for a particular activity as well as to indicate the size and dimensions of land area.

The final site suitability zonation map (Fig 8) indicates that maximum area is suitable for Residential development, followed by suitable sites for Reserve Forest area, Commercial development, waste disposal area, parking and recreational development area.

Table 15: Result Table

Name	Area (Acre)	Area(M2)	Total Area (Acre)
Parking	21.10021615	85389.53635	629.8228
Residential Area	137.8472367	557847.9171	
Recreation Area	18.04431268	73022.73504	
Reserve Forest	132.5099045	536248.502	
Waste Disposal Area	26.29951992	106430.37	
Commercial Area	65.94340942	266863.4821	

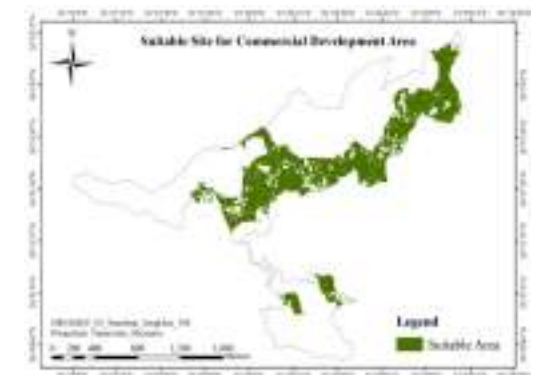

Figure 2: Suitable Sites for Commercial Development

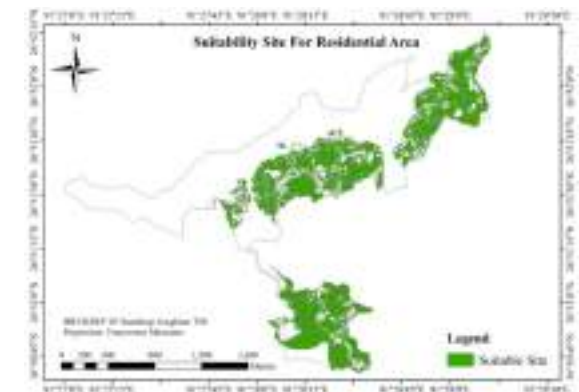

Figure 3: Suitable Sites for Residential Development



Figure 4: Suitable Sites for Recreational Development





Figure 5: Suitable Sites for Vehicle Parking Area



Figure 8: Suitable Sites for Reserved Forest Area



Figure 6: Suitable Sites for Solid Waste disposal



Figure 7: Suitability Site Zonation

## 6. CONCLUSION

This project conducted a Site Suitability Analysis to determine the best locations for Commercial, Residential, Recreational, Parking, Solid Waste Disposal Area and Protected Forest Area for Sustainable Town Planning in Dewathang using an integrated GIS-AHP model. The results confirm that the GIS-AHP model is a useful technique for environmental management and urban planning.

The suitable sites designated as a result for the project can be used by planning agencies for detailed urban planning and civil engineers for constructions.

## 7. ACKNOWLEDGMENT

We are indebted to thank Samdrup Jongkhar Thromde and National Land Commission Secretariat for providing necessary data required for the projects and also providing us important guidelines to make progress in our project.

We are very grateful to our guide Miss Tshering Choki and Co-guide Mr. Sanjit Kumar Bhattra for providing unlimited support, services and guidance in every steps of our project.

## REFERENCE

- Duc, T. T. (2006). Using Gis and Ahp Technique for Land-Use Suitability Analysis.
- Ebistu, T., & Minale, A. (2013). Solid waste

dumping site suitability analysis using geographic information system (GIS) and remote sensing for Bahir Dar Town, North Western Ethiopia. *African Journal of Environmental Science and ...*, 7(November), 976–989. <https://doi.org/10.5897/AJEST2013.1589>

Indexed, S., Ilayaraja, K., Singh, R. K., Rana, N., Chauhan, R., & Sutradhar, N. (2017). Site Suitability Assessment for Residential Areas in South Chennai Region using Remote Sensing and GIS Techniques, 8(8), 1468–1475.

Jain, K. (2007). *Journal of Applied Sciences*. Site Suitability Analysis for Urban Development Using GIS, 2576.

Kumar, M., & Shaikh, V. R. (2013). Site Suitability Analysis for Urban Development Using GIS Based Multicriteria Evaluation Technique. *Journal of the Indian Society of Remote Sensing*, 41(2), 417–424. <https://doi.org/10.1007/s12524-012-0221-8>

Maher MAburas, S. H. (2016). Urban Transitions Conference. Land suitability analysis of urban growth in Seremban Malaysia, using GIS based Analytical Hierarchy Process, 1128.

Tirusew Ayisheshim Ebistu, A. M. (2013). *African Journal of Environment Science and Technology*. Solid waste dumping

## Alarm Fencing and Light footpath sensor

Chencho Lhamo<sup>1</sup>, Dorji Singye<sup>2</sup>, Kinley Zangmo<sup>3</sup>, Kuenley Penjor Gyeltshen<sup>4</sup>, Pema Tshering<sup>5</sup>, Ratu<sup>6</sup>, Tashi Tenzin<sup>7</sup>, Younten Jamtsho<sup>8</sup>, Jagat Bdr. Ghalley<sup>9</sup>

Department of Electrical Engineering , Jigme Namgyel Engineering College  
Royal University of Bhutan, Dewathang, Bhutan

Email: [chencholhamo1997@gmail.com](mailto:chencholhamo1997@gmail.com)<sup>1</sup>, [dorjisingye995@gmail.com](mailto:dorjisingye995@gmail.com)<sup>2</sup>, [keenlayzangmo28@gmail.com](mailto:keenlayzangmo28@gmail.com)<sup>3</sup>, [kuenleypg999@gmail.com](mailto:kuenleypg999@gmail.com)<sup>4</sup>, [amepxring@gmail.com](mailto:amepxring@gmail.com)<sup>5</sup>, [Ratutenzin65@gmail.com](mailto:Ratutenzin65@gmail.com)<sup>6</sup>, [tashitenzin24@gmail.com](mailto:tashitenzin24@gmail.com)<sup>7</sup>, [cakaroteyounten157@gmail.com](mailto:cakaroteyounten157@gmail.com)<sup>8</sup>, [jagatbdr@jnc.edu.bt](mailto:jagatbdr@jnc.edu.bt)<sup>9</sup>

**Abstract-** This project titled “Alarm Fencing and Light footpath sensor” comprises of developing a model and a planned scheduled work that we must carry out in a specified period of time. It is one of the most efficient and helpful activities where we get the opportunity to expose ourselves to many new things and acquire ample of new knowledge. This project provide in-depth coverage of major topics like developing a model based on alarm fencing and light footpath sensor and the equipments used such as sensor, burglar alarms, resistors and circuit connection. The project idea comes in handy for farmers for security, i.e., to protect their crops from wild animals and also for home security.

**Keywords-**alarm fencing; light footpath sensor; PIR sensor

### 1. INTRODUCTION

Alarm fences began to be implemented ever since the World War II. The increased demand for detection and monitoring during that period generated technological advances in motion sensing. The alarm fences were used to control livestock in the United States of America and New Zealand. Samuel Bagno in the mid 1940s, using his knowledge of radar and newly developed electrical components began doing research on an ultrasonic alarm, which worked similar to radar. His ultrasonic alarm created “a web of ultrasonic waves inside a room” and detected the motion of a person. The detector “spins its web by establishing a pattern in the way that waves bounce off inanimate objects in the room and return to a receiver.” Movement shifts created disturbances in the pattern and triggered an alarm. The alarm fence is very versatile and one of its functions was in providing effective security solutions implemented in many applications.

Alarm fences are mostly used in agriculture. Whereas standard fences are constructed to just form a physical barrier, alarm fences are constructed to form both psychological and mental barriers. The mental barrier is accomplished by introducing a loud sound through the fence wire that both repels the animals and makes them less likely to contact the fence again. However in security systems, the sound and light indication are meant to keep intruders out and is usually accompanied by an alarm system. And this is what this project is aiming to achieve.

### 2. WORKING PRINCIPLE OF CIRCUITS

A. Touch Sensor The basic working principle of a touch sensor is that it detects proximity (also known as touch) without depending on the physical contact. Its working principle is same as simple switch or circuit. When any physical medium comes in contact with the touch surface, the internal circuit will be closed inside the sensor and current starts flowing which in turn activates the buzzer. [1]

B. Laser Light Sensor In this circuit we have set reference voltage of comparators by using potentiometer to see the sensitivity of the circuit. Comparator is configured in non-inverting mode. In this system we have to place laser light and LDR facing each other so that laser light continuously falls on LDR. Due to this, a potential difference is generated with reference voltage and generate a output as high. Before that we have to configured 555 timer in mono-stable mode so it requires a low trigger pulse so as to activate LED. If the output at comparator is high when laser light falls on LDR then it deactivates the LED. When someone crosses the laser light due to this LDR lost the laser light and generates a different potential difference across the same comparator terminal. Then the output of comparator is low and because of the low signal

to 555 timer gets a low trigger pulse and activates LED for a time period is defined by resistance and capacitance at 555 timer circuit [1].

### 3. WORKING PRINCIPLE OF MODEL

The working principle of the model is explained below.

The circuit model consists of laser circuit, touch sensor circuit, PIR sensor circuit and a transistor switch. Those circuits are interconnected through transistor working as relay switch. First PIR sensor is responsible for sensing the infrared radiation emitted by the living beings and activating the relay switch. When the transistor is activated through PIR sensor circuit, supply of 9V gets connected automatically to the circuit of touch sensor and laser circuit [2]. Touch sensor and laser sensor circuit are connected parallel to each other, so one supply is enough to activate those circuit. When a person or an animal comes in the range of PIR sensor circuit, circuit of touch and laser are automatically activated and deactivated when person or animal goes beyond the range of PIR sensor. During the day time laser circuit is not required, so it is put off by the switch at the control room [3], [4], [5].

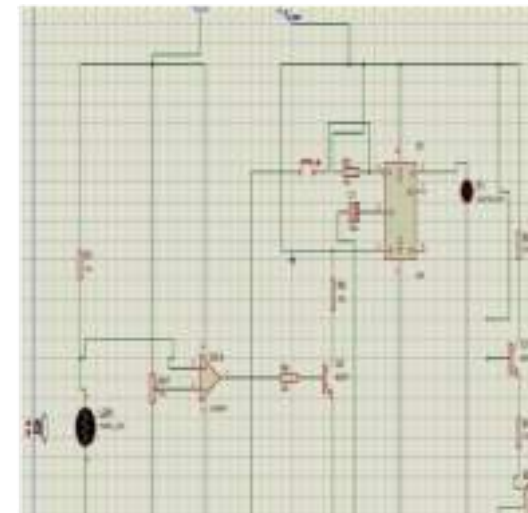

Figure 1: Circuit Diagram

### 4. FABRICATION PROCEDURES

The following are the procedures for the fabrication of the alarm fencing and light footpath sensor model.

- Design the circuit for the touch sensor, laser circuits, and PIR sensor using PROTEUS software
- Collect the materials required for the design.
- Demonstrate the circuit connection on the bread board as the circuit design
- Fabricate the circuit on the PCB board using the soldering machine
- Test the working of circuit.

### 5. WORKING MODEL

The fabricated working model is shown in Fig.2 below.



Figure 2: Fabricated model of alarm fencing and light footpath sensor.

### 6. ACKNOWLEDGEMENT

We would like to express our heartfelt gratitude to all the individuals who have helped us in completing our course project, “Alarm fencing and light footpath sensor”. We would like to extend our profound gratitude to the Management, Jigme Namgyel Engineering College for providing us with such an opportunity. Head of Department Mr. Chenga Dorji, project coordinator Mr. Karchung and all the panel members of Electrical Engineering Department for

their suggestions and necessary feedback during the midterm review which helped us proceed with our project. Furthermore we would like to acknowledge with much appreciation the crucial role of Mr. Jagat Bahadur Ghalley, who invested his full effort in guiding us and for his constant supervision as well as providing us with the necessary information to proceed with the project.

## REFERENCES

[1] Abhinav and Deshpande, Design and implementation of an intelligent security system for farm Protection from wild animals, International journal of science and research,10(2),2016, 300-350.

[2] Keller, Hans J.; Cima, D.: “Achieving High Reliability in Passive Infrared Intruder Alarms with Lithium Tantalate Pyroelectric Detectors”, Proc. SPIE, Vol. 395, pp 238-248, Geneva 1983

[3] Lang, Sidney B., „Sourcebook of Pyroelectricity“, Gordon and Breach, New York 1974

[4] Grant, John, „Intruder Alarms“, Paramount Publishing Ltd., Borehamwood, England 1991

[5]Rosch, Rainer; Zapp Robert; Hofmann Günter, Passiv-Infrarot Bewegungsmelder“, Bibliothek der Technik, Band 131, Verlag moderne Industrie, Landsberg/Lech 1996.

## Automatic Green Board Duster

Damcho Dema<sup>1</sup>, Sonam Yeshey Tshering<sup>2</sup>, Tashi Tshering<sup>3</sup>, Masanori Ogata<sup>4</sup>

Department of Mechanical Engineering, Jigme Namgyel Engineering College

Royal University of Bhutan, Dewathang, Bhutan

Email: damchodema1996@gmail.com<sup>1</sup> sonam.yeshey.tshering@gmail.com<sup>2</sup>, ttshering712@gmail.com<sup>3</sup>, ogata.world@gmail.com<sup>4</sup>

**Abstract—** *This project is implemented to make human work easier and can reduce the use of human effort because of its potential applications. The project Automatic Greenboard Duster is a device that is generally used to clean board automatically with the help of duster. The report puts forward a kind of mechanism design scheme; the mechanism of the automated board duster with a track structure entails a horizontal motion. The principle objective of the automatic greenboard duster is to provide an attachment for greenboard in the form of a power driven erasing by the rotary switch, thus eliminating the exhausting work of manually cleaning of greenboard.*

*This report contains the design and fabrication of Automatic Greenboard Duster. Cleaning of greenboard or blackboards consumes a lot of time while teaching. And also the dust obtained from the chalk while erasing the board affects the respiratory organ when inhaled by human. Therefore, we here propose an automatic greenboard mechanism that cleans the boards automatically with a duster. Our system uses a set of frames, guide ways, supporting shaft, slide bearings, motor, limit switch, rotary switch and a converter in order to achieve this mechanism. This system is designed to save time and unnecessary effort in cleaning the boards. For this purpose we use sponge (duster eraser) mounted on shafts which intern connected on a supporting frame. The electrical energy is converted into mechanical energy to move the duster in required directions.*

**Keywords-** *Automatic, Mechanism, design, fabrication, energy conversion*

## 1. INTRODUCTION

An automatic green board duster is a device that is generally used to clean board automatically with the help of duster. The inventions of greenboard were a revolutionary change in the history of mankind which led to the development of the society. One of the problems we are experiencing in classrooms is erasing the greenboard especially for the students who are sitting in front and the teachers. Cleaning of the boards makes teacher or the person who is cleaning dirty and also the scattering of the chalk dust is a serious health problem. Therefore, by the use of this automatic greenboard duster we can save time and energy. A device for automatically erasing a greenboard wherein a duster is mounted for horizontal movement on the greenboard and has a motor mounted thereon that is mechanically interconnected to a drive assembly for producing the movement of the duster in an erasing operation[2].

## 2. LITERATURE REVIEW

S.Joshibaamali and K.Geetha Priya has explained that the machine can operate in three selectable operational modes. In the first mode, it cleans the left side of the board. In the second mode it cleans the right side of the board. In the third mode it cleans the whole area of the board. The machine uses two stepper motors to move duster in horizontal (x-axis) and vertical (y-axis) direction. To move the duster in up and down direction linear motor is used. Infrared transceiver is used to detect horizontal direction of motor. Four limit switches are used to detect the boundary of the board [3].

Gaurav Gangurde, Sandeep Patil and Pratik Ugale explained that a duster is mounted for longitudinal movement on the blackboard and has a motor mounted thereon that is mechanically interconnected to a drive assembly for producing the movement of the duster in an erasing operation. They had used



the rack and pinion mechanism to convert the rotary motion of motor into linear motion of pinion and the system is set in operation by the throw of a switch [4].

Amit Tiwari, the assistant professor of Mechanical Engineering Department at Dungarpur College of Engineering and Technology (Rajasthan) in India, the mechanism can automatically detect the blackboard chalk stains, and erase the font, keep the blackboard clean. The duster includes a track structure to permit reciprocation of the duster laterally of an elongate blackboard frame. The chain which is connected to duster includes a drive motor to effect rotation of a drive duster positioned above the blackboard frame [5].

### 3. OVERVIEW OF THE SYSTEM

#### 3.1 Working mechanism

The motion of an automatic board duster entails in horizontal direction. The mechanism use to operate the duster is rotary motion to linear motion.[6] When a rotary switch is turn on, the motor transmits energy to pulley, which in turn drives the duster. The rotary switch consist of 4 poles and 6 positions in which 2 poles are connected to the motor and another two to the limit switch to place at two edges of the green board. The duster is fixed to the slide bearing which will move to and fro along the guide ways, thereby cleaning the board wholly.

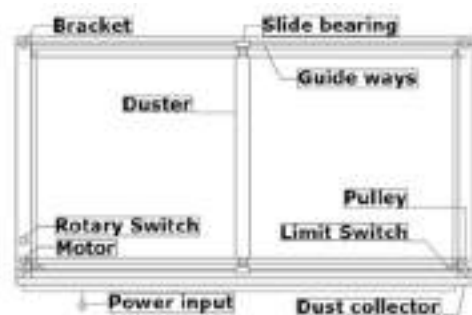

Figure 1: Overview of Duster

#### 3.2 Full control circuit

To move the duster in horizontal back and forth motion, the system require to convert electric energy into mechanical energy.[7] In this electric

component includes energy converter (to convert ac to dc), rotary switch, motor and two limit switches. The rotary switch consist of 4 poles and 6 positions in which 2 poles are connected to the motor and another two to the limit switch which is place at the two edges of the greenboard.

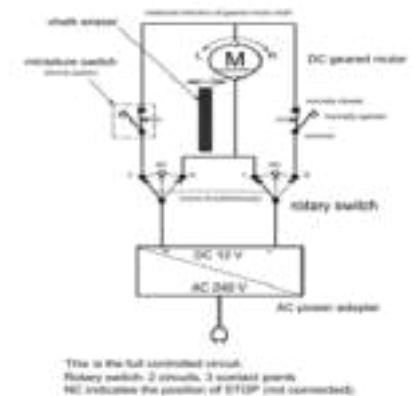

Figure 2: Circuit Diagram

#### 3.3 Constructional details

To support the whole structure and their components, a frame has to make using wooden bits. This wood was cut into the require dimensions (2400x80x25) mm and (136x80x25) mm by circular saw machine. The thickness of these wood is reduce to required size and shape by planer machine, followed by cutting of wood according to dimensions. After that paint and polish, the wooden frame. To move the duster horizontal it required a tract, known as guide way. It is fabricate of M.S of dimension (2600x12Ø) mm. The dust that produce from the chalk is collecting in U-Chanel made of G.I sheet to the dimension of (2400x60x40) mm. The side length of the sheet (60mm) is folded perpendicular to the base of the sheet and joined by riveting. The duster frame is made of G.I of dimension (1200x80x40) mm and along it attached with sponge to eraser the board. To run duster along the guide ways, it require pulley of size (50mmØx15mm), which is finishing in lathe operation.

### 4. CONCLUSION AND FUTURE SCOPE

In conclusion, this automatic green board cleaner is a device use to clean the board. The operation of the duster is semi-automatic that's move in horizontal

direction. It found that the board is clean in single stock, where do not require repeating the cleaning on the board. It also observed saving of time. In these project , it is observed that the DC gear motor (12V/16.8 rpm) has low speed and the guide ways (2600x12Ø)mm is sagging which is causing problem in the movement of duster. Therefore, in future it is a great scope to modify it in different ways like using a higher-powered motor and guide ways with rigidity materials.

### 5. ACKNOWLEDGEMENT

We would like to express a deep sense of thanks and gratitude to;

Project guide Professor Masanori Ogata for guiding us immensely through the course of the project.

Head of mechanical department and staff for their constant advice and support.

Lastly, appreciation goes to my classmate and colleagues who have willingly helped us with their abilities.

### REFERENCES

- [1] "Chalkboard Eraser." [Online]. Available: [http://nevon\\_projects.com/automatic-blackboard-whiteboard-cleaner-system](http://nevon_projects.com/automatic-blackboard-whiteboard-cleaner-system) [Accessed: 10May 2018]
- [2] Santhosh, T.U., Anvesh, V., & A Vinutha.

(2016). International Journal of Latest Research

In Engineering and Technology (IJLRET). esign and Fabrication of an Automatic Blackboard Cleaner. 02(12), 15-35.

[3] S.Joshibaamali And K.Geetha Priya, (March, 2015). International Journal Of Emerging Technology In Computer Science & Electronics (IJETCSE), Automatic Duster Machine, ISSN: 0976-1353 Volume 13 Issue 1

[4] Gangurde, G., Patil, S., Ugale, P., Wagh, S., & Mahindrakar, A. (2016). International Journal of Engineering Technology, Management and Applied Sciences. A Review of Automatic Blackboard Cleaning System. 4(2), 208–211.

[5] Tiwari, A. (2015). International Journal of Emerging Technology and Innovative Engineering. Design and Fabrication of Automatic Blackboard Duster. 1(2), 44-52.

[6] Ugale, V. D., Marathe, A., Ashutosh, T., & Ugale, N. (2015). International Journal of Advanced Research in Electronics and Communication Engineering (IJARECE). Automatic blackboard eraser, 4(4), 1052–1056.

[7] Engineering, I. (2015). International Journal of Emerging Technology and Innovative Engineering "DESIGN AND FABRICATION OF AUTOMATIC BLACKBOARD DUSTER," 1(2).

**ABSTRACT- This paper presents on smart metering system. Now-a-days, technology has developed to a large extent. At the same time the need for systems with automation are preferred. The traditional and conventional meter reading has problems in calculating the readings and billing as it is manual. With growing number of consumers it is becoming difficult to maintain the power as per the requirements. A human operator has to go to the consumer's house and provide the bill as per the meter reading. Going to each and every consumer's house and generating the bill is a laborious task and requires lot of time. If any consumer does not pay the bill, the operator needs to go to their houses to disconnect the power supply. These processes are time consuming and difficult to handle.**

**The proposed work has developed automatic energy meter reading using GSM module. It measures energy consumption through LDR sensor. The LDR sensor is placed on energy meter which senses the LED blinking pulse. These pulses are counted by microcontroller AT89S52. The unit will be displayed on LCD which is interfaced with the controller. The units consumed per month will be send to the consumer via SMS using GSM modem.**

**Keywords—GSM energy meter, load control, LDR, Micro-controller AT89S52, GSM SIM900**

### INTRODUCTION

Electrical power has become indispensable for human survival and progress. At the present scenario, meter reading for electricity consumption and billing is done manually collecting data from house to house. To meet growing demand, automation in the energy distribution is also necessary to enhance people's living standard and respect privacy. This project deals with Fabrication and Simulation of GSM based energy meter. An energy meter is a

device that measures the amount of electric energy consumed by a device. The smart energy meter is less time consuming and cost effective. The purpose of this project is to get automatic reading of electrical energy consumed which is sent to the consumer's specified number through GSM modem. It becomes difficult particularly in monsoon, if any consumer does not pay the bill, the operator needs to go to their houses to disconnect the power supply. Increase in manual task leads to increase in human resource. Thus the present system of energy reading results in many drawbacks such as excessive manpower requirement, human errors and inability of users to keep track of their energy consumption record leading to overall increase in cost.

### 1. PROBLEM STATEMENT

The energy meter which is placed at the consumer premises needs manual data collection and calculation in order to generate an invoice bill. Manual work requires an individual service operator to visit household every month and meter reading can be tampered, leading to errors.

### 2. LITERATURE REVIEW

To overcome the existing drawbacks of conventional meter reading, a technique has been presented for extracted information about energy usage from a remote location. According to [1] the GSM infrastructure, its nationwide coverage and the Short Messaging System (SMS) cell, broadcast the feature to wirelessly transmit the individual house/organization power consumption readings. As per the research [2] it shows that one can reduce the tedious work with respect to the monitoring and load control of the consumers energy meter with the application of GSM based energy meter monitoring and load control, in which just by sending the required message to the specified numbers, the customer will be able to find out the total unit the energy consumed.

The energy meter reading which is done by the

microcontroller unit which continuously monitors and records the energy meter readings in its memory location in the microcontroller unit. In his project he unit. The used a GSM modem for remote monitoring and control of energy meter by sending a SMS to the reason for coming up with this project was to avoid energy theft and allow automatic data collection and information system [3]. In [4] a simple low-cost wireless GSM energy meter and its associated web interface, for automating billing and managing, the collected data, globally is designed. The proposed system replaces traditional meter reading methods and enables remote access of existing energy meter by the energy provider. A computer is also connected with the GSM receiver at the other end, which contains the database and acts as the billing point. Live meter reading from the GSM enabled energy meter is sent back to this billing point periodically and these details are updated in a central database. A new interactive, user friendly graphical user interface is developed using Microsoft visual studio .NET framework and C#. With proper authentication, users can access the developed web page details from anywhere in the world. The complete monthly usage and due bill is messaged back to the customer after processing these data.

According to [5] the GAPMR system consists of GSM digital power meters installed in every consumer unit and an electricity e-billing system at the energy provider side. The GSM digital power meter (GPM) is a single phase IEC61036 standard compliance digital kWh power meter with embedded GSM modem which utilize the GSM network to send its power usage reading using short messaging system (SMS) back to the energy provider wirelessly. At the power provider side an electronic billing system is used to manage all received SMS meter reading, computing the billing cost, updating the database, and to publish billing notification to its respective consumer through SMS, email, Web portal and printed postage mailing. A working prototype of the GAPMR system was built to demonstrate the effectiveness and efficiency of automatic meter reading, billing and notification through the use of GSM network. According to [6] it represents an implementation methodology for a wireless automatic meter reading system (WAMRS) incorporating the widely used GSM and Zig-bee network.

In many countries GSM and GPRS network is widely known for its vast coverage area, cost effectiveness and also for its ever-growing market. Using GSM as the medium for WAMRS provides a cost effective, wireless, always-connected, two-way data link between the utility company and the WAMRS. The WAMRS sends information of utility usage, power quality and outage alarms to the utility company, tampering detection to the utility server. In this paper we suggest a method where we utilize telecommunication systems for automated transmission of the data to facilitate bill generation at the server end and also to the customer via SMS, Email

Where as in [7] they proposed a system, which measure the current consumption unit through IR sensor unit. The IR transmitter is placed in the rotating unit of the EB meter. The receiver photo diode is placed in a certain place which is used to find no of rotation. By getting the number of rotation they got the current consumption. After getting the current consumption the ARM processor will reduce the unit given for specific user. The unit here is taken as numeric value. If the unit is reduced to minimum value it will intimate the user through alarm and LCD unit. If the user wants to add more units for him, he has to send a message to EB section. From the EB section the required value will be sent to the ARM controller through GSM modem.

### 3. INTERFACING OF LCD WITH MICROCONTROLLER

Here the circuit diagram of the LCD display is as shown below, where as in our project we have used the port 0 for interfacing of the LCD display, also we have given the potentiometer for varying the required intensity. Moreover we have used the 16\*2 LCD as the length of the lines which to be displayed are minimum and are satisfied by the required model, one can also use bigger size of the LCD display for the required use. The LCD here is used for displaying unit and pulse of the energy meter. It also acts as an interface between user and power meter.

### 4. SIMULATION

Since we have used DIGITAL ENERGY METER for the project purpose, we have to take the pulses out to show that how much energy is consumed by the user. For simulation purpose we have used the



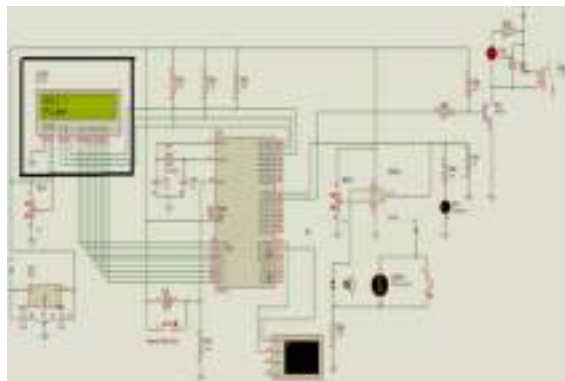

Figure 1: Interfacing LCD with microcontroller

toggle switch instead of LDR because energy meter is not available in proteus. But in practical we will be placing the LDR on the top of Cal LED of the energy meter, so that microcontroller counts the pulse when the Cal LED blinks.

## 5. BLOCK DIAGRAM

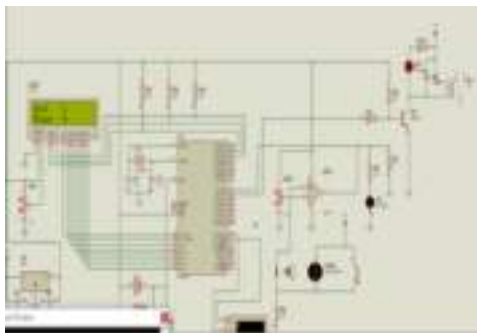

Figure 2 (a): Simulation to obtain pulse from energy meter

The figure above shows the proposed block diagram for GSM based energy meter. Here microcontroller is main part which control and monitor whole system. And also it interfaced with various devices like LCD, energy meter, relay and GSM module. The power supply to microcontroller is 5V. Firstly LDR is interfaced to controller. Here the LDR is used as a sensor, it senses the blinking rate of LED which is present on energy meter. It is used as an indicator, when power is consumed the LED blinks. When LED blinks 3200 times than 1 unit power is consumed by the devices. It sends the signal to the LDR. And then LDR sends the pulses to the microcontroller. Inside the programming the user's number will be specified and the unit consumed per

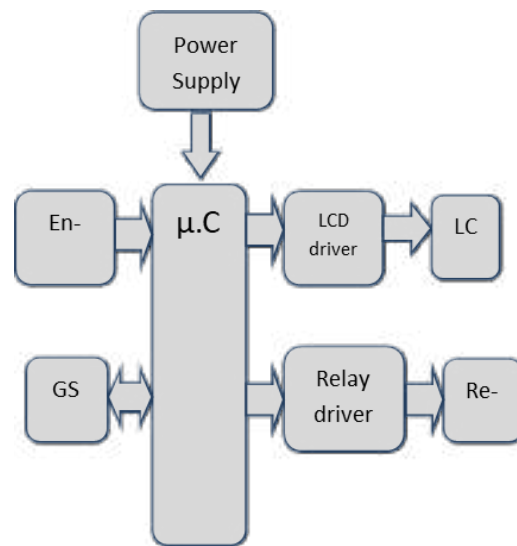

Figure 2 (b): Block diagram

month will be send to user by SMS through GSM modem. Also LCD is interfaced with controller. LCD is the display unit, the total units are counted by the micro controller and then displayed on the LCD. Relay circuit will act as a load control.

Whenever the consumer fails to pay the bill on time, these relay will cut-off the load of the consumer's.

## 6. CIRCUIT TESTING

The test result for individual components were positive and was proceeded for fabrication. After the testing of the components, fabrication was started on the single sided printed circuit board, making detection and error correction of any layout error difficulties.

The construction process using printed circuit board involved soldering components to the nominated position on the printed circuit board. All components were labeled on the designs notes and on the printed circuit board itself. Due to the nature of the layout, all components had to be connected before testing could take place.

The performance of the electronic circuit depends on the layout and design of printed circuit board therefore soldering was done carefully.

Soldering is the joining material that melt below 270°C between components. The popularly used

solder are alloy of tin (Sn) and lead (Pb) that melts below melting point of tin.

Soldering iron is a tool used to melt the solder lead and apply it at the joint in the circuit. It operates at 230V supply. The 50 Watt soldering irons are commonly used for the soldering of electronic circuit. The fabrication of components depends on the soldering ways.

## 6.1 .KEIL COMPILER

KEIL Micro Vision is an integrated development environment used to create software to be run on embedded systems. It allows software to be written either in assembly or in C programming languages

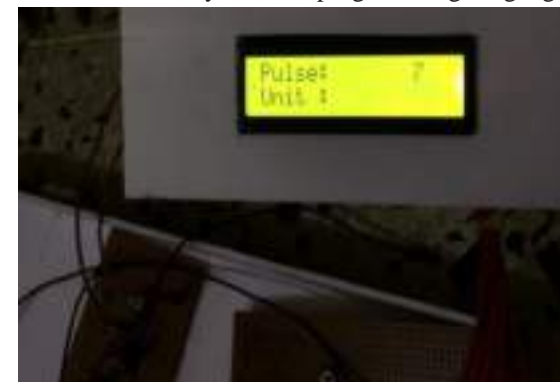

Figure 3: Circuit Testing

and for that software to be simulated on a computer before being loaded onto the microcontroller unit. We are using the c programming.

## 6.2 PROTEUS



Figure 4: KEIL COMPILER

Proteus is electronic circuit design software which includes a schematic capture, simulation and PCB layout modules. Proteus is ahead in simulating the circuits containing the microcontrollers where

we can simulate the circuit by uploading the hex code to microcontroller.

## 6.3 ALGORITHM

```

START
SET PULSE=0
SET UNIT =0
SET RELAY =0
SET TARGET PHONE NO= 17982074
INITIALIZED SERIAL COMMUNICATION
INITIALIZED LED
DISPLAY INTRODUCTION
WAIT FOR 100 MS
CLEAR LED
DISPLAY "PULSE"
DISPLAY "UNIT"
INITIALIZED GSM MODEM
LOOP
IF SENSOR IS HIGH (DETECT PULSE) THEN
INCREASE THE PULSE BY 1
DISPLAY THE PULSE VALUE ON LED
IF PULSE =0 THEN
INCREASE UNIT BY ONE
DISPLAY UNIT VALUE
WRITE TO GSM ('AT + EMGS= ')
WRITE TO GSM (TARGET PHONE NO)
WRITE TO GSM (UNIT)
SET PULSE =0
END IF
END IF
C= READ FROM GSM MODEM
COMMAND =COMMAND +C
IF C= '*' THEN
COMPARE COMMAND
IF COMMAND ="#CUT" THEN
SWITCH OFF THE RELAY
  
```



```

END IF
IF COMMAND=# RESUME "THEN
SWITCH ON THE RELAY
END IF
END IF
GO TO LOOP

```

## 10. ANALYSIS

With the completion of our project, we were able to get the pulses and the unit consumed by the energy meter. As the LED blinks one time, the LDR will read one pulse and like that 10 pulses will make 1 unit. 1 unit is made as a unit consumed per month. As soon as the unit reaches to 1, the consumer will receive the SMS.

This project deals only with the unit consumed per month and sending it to consumer while [5], [4], [2] deals with the unit consumption, computation of the bills and then sends the bill to the consumer via a SMS. This project uses LDR to sense the blinking light of LED which counts the pulses while [3] uses opto-coupler to read the pulses.

## 11. RESULT

The energy meter was tested by using an electric light bulb of 100 watts that draws current up to A. The supply voltage was 230V. The time required to make one pulse was tested with the help of timer clock the time found out was approximately 10 sec. The pulse is incremented after every 10 sec and is displayed on LCD. The test was done over two minute's period and measurements were taken every 10 seconds. The result is shown in Table 1.

Table 1: Average Time Required to Read One Pulse

No. of test	Time required to read one pulse (seconds)
1	9.12
2	8.91
3	9.35
4	10.12
5	9.90
6	10.0
7	9.81
8	9.12
9	8.89
10	9.10

For the demonstration purpose the SMS gate way GSM modem uses an ordinary SIM card phone number. The 100W light bulb is used to simulate the power consumption load and the meter capture the reading as shown in figure 6. When the unit consumed by the load is 10 pulses which make one

## 7. HARDWARE USED

The hardware used in this project: energy meter which measures the amount of electric energy. Microcontroller are also used which is interfaced with GSM modem and LCD. Through GSM, the consumers are connected and LCD is used to display the units and pulses consumed by the energy meter. Resistors and capacitors are also used.

## 8. ADVANTAGES

The process of energy meter reading and delivery of monthly bills to customers will consumes less time as the monthly bill will be sent to the consumer's number through the system. It eliminates the need of operator to visit individual house to read the meter and deliver the bills which saves cost on human resources.

A convenient and efficient method to avoid the problem of electricity department sending employees for taking meter reading every month.

If any consumer did not pay the bill, the operator needs to go to their houses to disconnect the power supply. These processes are time consuming and difficult to handle. No human errors in taking the meter readings.

Economical and simple to use as the human operator doesn't need to have to go to individual house to collect the data it saves money and on the other the customers also don't have to go to pay the bill.

## 9. DISADVANTAGES

It leads to initial hesitation of people to upgrade to this system. The installation expenditure will be high.



Figure 5. Variation in time required to read one Pulse unit, the GSM modem successfully sends this unit to the registered user's phone through SMS.



Figure 6 : Result

## 12. COST ANALYSIS

It is tedious and cost enduring to employ numerous data collector by the energy company, for the purpose of meter reading and generation of monthly invoice. For example: In Bhutan there are 205 Gewogs, each Gewog requires minimum of two men to collect the bills and they are paid monthly salary of 10,000. In total the BPC has to pay 410 people per month which cost 410 x 10000=4,100,000 amount per month and annually they have to invest 41 lakhs. So if they implement GSM Based energy meter reading, the initial cost will be 9000 only and it is one time implementation. Thus BPC will minimize 49 million per year which is a great achievement and they can utilize this amount for others purposes.

## 13. FUTURE SCOPE

Since this project focus on the reading of the energy meter and controlling the load through GSM, developers can also bring changes which will be beneficial to both the consumers and Energy Company by making the fixed usage manual. This will make recharging user defined with the per-

paid plans that can be selected through registered SIM cards. One up gradation can be including the feature of instant bill. With these features consumer can know their bill at any interval of the month, so that an economical consumer can vary his/her consumption. Also a timer control can be provided, which would automatic cut down the system supply, if the payment of bill is not done in the specified time limit.

## 14. CONCLUSION

With this project we can make system easy and less time consuming. This project will reduced the disadvantages of the present system. One can establish user friendly and direct interfacing between the consumer and the distributor without any external interference. Also with this, the accuracy of the system increases as the gross errors, observational errors, etc. decreases. Thus with this we can conclude, that a time efficient, reliable, and accurate system analysis can be obtained which is indeed economical and user friendly.

## REFERENCES

- [1] Priyanka Dighe. "GSM Based Energy Meter". Vol. 3, pp. 12-14
- [2] Darshit S. Patel and H. B. Patel. "GSM Based Energy Monitoring and Load control". Vol. 4, pp. 360-363, March, 2017
- [3] Praveen Kumar. "GSM Based Automatic Energy Meter Reading With Load Control". Vol.4, pp. 1428-1432, 5th May 2015
- [4] Ashna.k and Sudhish N George. "GSM based Automatic Energy Meter Reading System with Instant Billing." Pp. 65-71, 2013
- [5] H.G.Rodney Tan, C.H and Lee, V.H.Mok. "Automatic Power Meter Reading System Using GSM Network". Vol. 3, pp. 465-469, 24th July, 2009
- [6] S.Arun and Dr.Sidappa Naidu. "Design and Implementation of Automatic Meter Reading using GSM, ZIGBEE through GPRS". Vol. 3, pp. 355-358, March, 2007
- [7] E.Moni Silviya, K.Meena Vinodhini and Salai Thillai Thilagam.J "GSM Based Automatic Energy Meter System with Instant Billing". Vol.3, pp. 44-49,

[8]. Subhashis Maitra, “Embedded Energy Meter- A new concept to measure the energy consumed by a consumer and to pay the bill”, Power System Technology and IEEE Power India Conference, 2008.

[9] Yujun Bao and Xiaoyan Jiang, “Design of electric Energy Meter for long- distance data information transfers which based upon GPRS”, ISA 2009. International Workshop on Intelligent Systems and Applications, 2009.

[10] Amin S. Mehmood, T. Choudhry, M.A. Hanif, “A Reviewing the Technical Issues for the Effective Construction of Automatic Meter Reading System” in International Conference on

[11] Vivek Kumar Sehgal, Nitesh Panda, Nipun Rai Handa, “Electronic Energy Meter with instant billing”, UKSim Fourth European Modelling Symposium on Computer Modelling and Simulation.

[12] Bharath P, Ananth N, Vijetha S, Jyothi Prakash K. V. “Wireless automated digital Energy Meter”, ICSET 2008.

[13] Sachin Divate, Tanaji Dhikale, Trunal Dube, Milan Mitke “REMOTE WIRELESS AUTOMATIC METER READING SYSTEM” International Journal of Emerging Technology and Advanced Engineering (ISSN 2250-2459, ISO 9001:2008 Certified Journal, Volume 3, Issue 4, April 2013)

## Effect of Inventory Management on The Profitability of Two Manufacturing Companies – A Case Study

Dorji Lhamo<sup>1</sup>, Kinga Tshering<sup>2</sup>, Pabita Mongar<sup>3</sup>, Tempa Rabgye<sup>4</sup>, Karma Drukpa<sup>5</sup>

Department of Humanities and Management, Jigme Namgyel Engineering College,  
Royal University of Bhutan, Dewathang, Bhutan

Email: dorjilhamo96@gmail.com<sup>1</sup>, kingatshering555@gmail.com<sup>2</sup>, pabitamongar123@gmail.com<sup>3</sup>,  
rabgye56@gmail.com<sup>4</sup>, karmadrukpa@jnec.edu.bt<sup>5</sup>

**Abstract**—This paper studies the effect of Inventory Management on the profitability of two manufacturing companies in Pasakha, Bhutan. It is mainly to identify the key factors that influences inventory management practices and evaluate the performance of the identified companies. Mixed method approach was adopted for the comparative study on the profitability of the two manufacturing companies. The study found that the company with low inventory cost performs better in maximizing the profit. Thus, the result of the project is expected to minimize the inventory cost for manufacturing companies to maximize the profit.

**Keywords**—inventory cost, inventory management, profitability.

### 1. INTRODUCTION

Raw materials take a major share of 50 to 70% of the total cost [1], in addition, one third of the company’s total investment is in the form of work in progress, finished goods and store inventory. Out of the three inventory forms, the store inventory usually represents the largest share and this is the area which significantly contributes to the company’s profit by efficient management of quantity and timing of purchases. If limited quantity is purchased, the unit cost will be high, shortages are likely to increase, expediting work will unnecessarily be greater and relationship between vendor and supplier will suffer. On the other hand, if large quantity is purchased, the excess inventory will raise costs, obsolescence will become an issue and the need of additional storage facilities will create investment problems.

Better financial performance is closely related with better inventory management as inventory takes the major share of the total cost. Failing

to maintain proper inventory level, will result in loss. Appropriate inventory level depends on the production schedule and market demand of the product. Inventory is a current asset to a firm, but it is costly to maintain as it waits to be converted into future sales. Therefore, factors influencing inventory management such as inventory control, economic order quantity, procurement cost and carrying cost have to be considered to increase the efficiency and profitability of manufacturing company.

#### Problem statement

It has been found that no relevant studies on inventory management practices were conducted to identify the performance of the manufacturing companies in Bhutan. Such studies are expected to bring enormous benefit for efficient and effective operation of business organization. Therefore, a case study on the factors affecting inventory management and their effects on the profitability of two manufacturing companies such as Druk Wang Alloys Limited Company (DWAL) and Druk Ferro Alloys Limited Company (DFAL) located in Pasakha, under Phuentsholing Thromde was decided for the project.

#### Objectives

The objective of the study is:

To identify the factors affecting inventory management in the manufacturing company.

To identify the common factors affecting the profitability in manufacturing company.

To perform comparative study on why one company is performing better than the other.

#### Scope

This study will be limited to identifying the factors affecting inventory management and the

profitability of two manufacturing companies in Pasakha. It will also perform comparative study on why one company is performing better than other considering those factors.

## 2. LITERATURE REVIEW

Inventory being a major portion of total current assets of many manufacturing companies, it often represents as much as 40% of the capital of industrial organization. Inventory represent 33% of a company's assets and as much as 90% of working capital [4]. Manufacturing companies attain significant savings from effective inventory management, which amounts between 50%-60% of total costs. Effective management of inventory can lead to a reduction in cost, resulting in a significant saving. A potential 6% saving on total cost through effective inventory management is achievable [3]. Inventory cost should be considered while taking inventory decisions. He found that inventory carrying costs typically range from 20% to 40% of inventory value [6]. The excess inventory and shortage of materials are often the two main problems found in manufacturing companies. One of the reasons for keeping large amount of inventory items has been related to customer service [5]. Another reason is that smaller purchasing lots imply more work in purchasing department. The excess inventory is an operational liability, because it uses valuable storage space, increases inventory costs [3].

A project to improve inventory management in UK- small medium enterprises found the importance of categorizing stock and setting ordering policies. A scheme developed for placing order has found useful in optimizing inventory costs [2]. The studies found that inventory has to be calculated using inventory policy parameters that is maximum and minimum inventory level of order placement [7].

## 3. METHODOLOGY

To achieve the objectives mentioned, the factors affecting inventory management in two manufacturing companies will be identified using qualitative method. As per the literature review factors such as economic order quantity, ordering cost, carrying cost, and inventory control affects the inventory management in manufacturing companies. In order to study these factors affecting the profitability of the two manufacturing companies,

questionnaires will be prepared based on the identified factors; visit the two identified companies and conduct face-to-face interview.

To find out why one company is performing better than other in terms of the profitability and effects of inventory management on profitability, quantitative analysis will be performed using following ratios and bar graphs to represent the values in figures.

Return on Assets: This ratio will be used to find out how efficiently the two manufacturing companies are employing their assets in the production and it is calculated by:

$$\text{RoA} = \frac{\text{Profit}}{\text{Asset employed}} \quad (1)$$

Where:

Profit = Annual Sale – total inventory cost incurred

Assets Employed = fixed assets + current assets

Return on Sales: This ratio will be used to evaluate a company's operational efficiency. Return on sales will be used to indicate how much profit is being produced with respect to sales. An increasing return on sales indicates that company is growing more efficiently, while a decreasing return on sales could signal impending financial troubles. Therefore, it is calculated by:

$$\text{RoS} = \frac{\text{Profit}}{\text{Annual sales}} \quad (2)$$

Return on inventory cost: this ratio of profit to total inventory cost of the company is the ratio that describes the return on per unit of inventory cost spent in process of production. Company's efficiency can be considered better if their return on inventory cost is higher.

$$\text{RoIC} = \frac{\text{Net profit}}{\text{Total inventory cost}} \quad (3)$$

Where: Total Inventory cost = total ordering cost + total holding cost

## 4. RESULT AND DISCUSSION

### 4.1 Findings

The economic order quantity, ordering cost, carrying cost, and inventory control are the factors that affects the inventory management in manufacturing companies. However, while visiting the company it was found that factors such as economic order quantity, inventory control, ordering cost and carrying cost exist in the company but, the management of the company were unaware of such factors. They do not identify the inventory management factor and how that affects the profitability of the company. It was also found that rather than calculating the economic order quantity for carrying and ordering inventory, the company set their own level that is maximum, minimum and reorder point as per their previous years' experiences, daily usage and demand trends. Ordering cost and carrying cost are considered as

general expenses, though it is an inventory cost. Thus, they do not emphasize on how to reduce such cost to increase efficiency of inventory management in the profitability. In terms of inventory control system, they keep record of how much raw materials are being used in daily basis and how much balance inventory are left in Tally ERP9, but no separate cost for spoilage, obsolescence, theft and stock out were maintained considering the company as continual manufacturer.

As stated above, inventory cost (ordering cost and carrying cost) are main and common factors that affect the profitability of the two companies. From the following table it can be seen that DFAL is incurring higher ordering cost compared to DWAL.

### 4.2 Ordering cost

From the table 1 below after taking into consideration of ordering cost of DWAL in 2016.

Table 1: Total Ordering Cost of DWAL & DFAL

Sl. No	Cost	DWAL (Nu.)		DFAL (Nu.)	
		2016	2017	2016	2017
1	Paper	6,900	7,020	2,900	3,000
2	Cartridge and printing	16,400	16,800	26,820	27,000
3	Electricity	17,800	18,000	4,490	4,598
4	Phone bill	49,000	48,000	49,000	50,000
5	Water bill	6,240	6,240	1,825	1,935
6	Rent	30,855	30,855	32,550	32,550
7	Salary	1,140,000	1,140,000	1,013,760	1,013,760
8	Other expense	1,95,580	1,95,600	80,100	80,640
Total ordering cost		1,462,775	1,462,515	1,211,445	1,213,483

Table 2: Total Carrying Cost of DWAL & DFAL

Sl. No	Cost	DWAL (Nu.)		DFAL (Nu.)	
		2016	2017	2016	2017
1	Taxes on Inventory	6,37,904	1,432,550	1,850,000	2,000,000
2	Insurance	1,562,653	1,579,828	2,000,000	2,200,000
3	Lighting	15,000	15,600	13,780	14,000
4	Repair Cost	5,23,430	4,07,541	1,800,000	2,000,000
5	Phone bill	2,39,000	2,40,000	1,52,000	1,54,000
6	Water bill	6,240	6,240	3,000	3,000
7	Salaries and Wages	1,38,000	1,38,000	6,95,304	6,95,304
Total carrying cost		3,122,227	3,819,759	6,514,084	7,066,304



It was found that it affects the profitability of the company, where the sale of DWAL in 2016 was Nu. 1,229,374,821 and total ordering cost was Nu. 1,462,775. After deducting total ordering cost from sales, the profit of the company decreased to Nu. 1,227,912,046.

Similarly, for the following year of DWAL and for the year 2016 and 2017 of DFAL, it was found that increase in ordering cost has resulted in decrease of the profitability of the two companies.

#### 4.3 Carrying cost

From the table 2 taking into consideration of carrying cost of DFAL in 2017. It was found that carrying cost affects the profitability of the company, where the sale of DFAL in 2017 was Nu 998,744,298 and the total carrying cost was 7,066,304. After deducting total carrying cost from sales the profit of the company reduced to 991,677,994.

Table 3: Profit and Assets employed of DWAL & DFAL

Companies	Profit		Assets employed	
	2016	2017	2016	2017
DWAL	1,224,789,819	1,228,764,003	7,04,208,366	5,85,889,294
DFAL	7,27,783,271	9,90,464,511	6,65,000,000	7,62,000,000

Similarly, for the previous year of DFAL and for the year 2016 and 2017 of DWAL increase in carrying cost has resulted decrease in the profitability of the two companies.

#### 4.4 Return on assets

Return on Assets of DWAL in 2016 was found to be 1.74 using equation 1 and taking profit and assets employed from table 3 to find out how efficiently the company is employing their asset in production.

$$RoA = \frac{1,224,789,819}{7,04,208,399} = 1.74$$

Similarly, for the following year the RoA was calculated in the same manner for the two companies, which is shown in table 4.

Table 4: Return on Assets of DWAL & DFAL

Return on Assets		
Companies	2016	2017
DWAL	1.74	2.1
DFAL	1.09	1.3

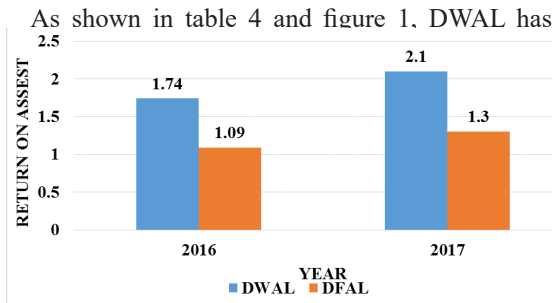

Figure 1: Return on Assets of DFAL & DWAL

higher return on assets than DFAL. This is because DWAL has less inventory cost than DFAL which has lesser impact on profitability as compared to DFAL. This indicates that DWAL uses their assets more efficiently than DFAL by reducing its inventory cost.

Table 5: Profit and Annual Sales of DWAL & DFAL

Companies	Profit		Annual Sales	
	2016	2017	2016	2017
DWAL	1,224,789,819	1,228,764,003	122,937,4,821	1,234,046,277
DFAL	7,27,783,271	9,90,464,511	7,35,508,800	9,98,744,298

Return on sales of DFAL for the year 2016 was 0.98 calculated by using equation 2, taking profit and annual sales from table 5 to evaluate company's operational efficiency.

$$RoS = \frac{7,27,783,271}{7,35,508,800} = 0.989$$

Table 8: Return on Inventory cost of DWAL & DFAL

Return on inventory cost		
Companies	2016	2017
DWAL	8.58	21.55
DFAL	5.08	11.94

Similarly, RoS of two companies was calculated in the same manner, which is shown in table 6.

Table 6: Return on Sales of DWAL & DFAL

Return on Sales		
Companies	2016	2019
DWAL	0.996	0.996
DFAL	0.989	0.992

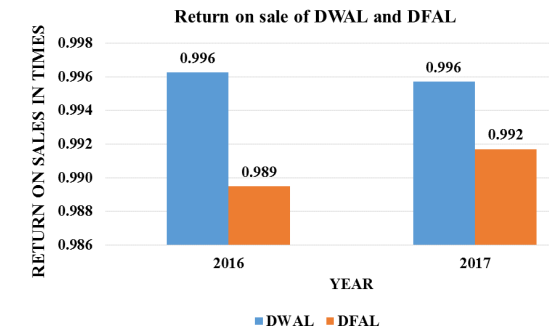

Figure 2: Return on Sales of DFAL & DWAL

As displayed in table 6 and figure 2, DWAL has higher return on sales than DFAL because DWAL has less inventory cost that affect the profitability compared to DFAL. Therefore, DWAL is growing more efficiently as compared to DFAL as they maintain lower inventory cost.

#### 4.5 Return on inventory cost

Table 7: Net profit and Inventory cost of DWAL & DFAL

Companies	Net Profit		Inventory cost	
	2016	2017	2016	2017
DWAL	39,318,124.70	1,13,849,155.7	4,585,002	5,282,274
DFAL	39,221,303.30	98,834,552.60	7,725,529	8,279,787

Return on inventory cost for DWAL for year 2017 was calculated using equation 3, taking profit and inventory cost from table 7 to determine the return on per units of inventory cost spent in process of

$$RoIC = \frac{1,13,849,155.7}{5,282,274} = 21.55$$

production.

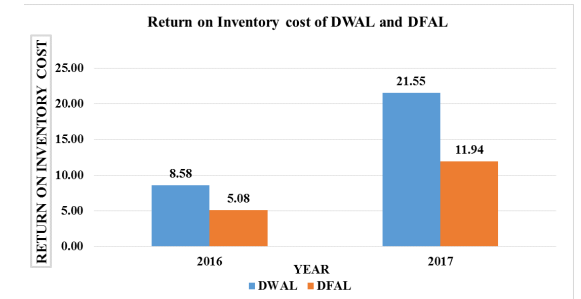

Figure 3: Return on inventory of DFAL & DWAL

Similarly, the return on inventory cost for DWAL in 2016 and For DFAL in the year 2016 and 2017 was calculated in the same manner, which is shown in table 8.

As shown in table 8 and figure 3, the return on per unit of inventory cost spent in process of production for DWAL is higher than DFAL because DWAL has less inventory cost compared to DFAL.

## 5. CONCLUSION

From the above results and discussion, it is concluded that ordering and carrying cost are the key factors affecting profitability of the two companies. Increase and decrease of inventory cost is inversely proportional to the profitability. It is seen that increase in inventory cost of DFAL has led to decrease in profitability, whereas DWAL maintained lower inventory cost which led to increase in profitability. It was also found that increase in inventory cost leads to decrease in company's efficiency of using assets, affects the growth of the company and reduces returns on investment. Therefore, to increase the profitability of the company, inventory cost has to be assessed, monitored and controlled.

## 6. RECOMMENDATION

The study recommends the manufacturing companies to maintain a separate inventory cost from general expenses then they can emphasize on reduction of inventory cost to increase efficiency of inventory management for profit maximization.

Further, it also has a scope for similar study on more than two manufacturing companies to compare their performance and examine other factors such as economic order quantity, and efficient management of inventory; which affects the small-scale business.

Moreover, it can be used as reference to carry out research on similar topic such as “effects of inventory management on cost” or “effects of inventory management on the efficiency of the manufacturing company”.

## 7. ACKNOWLEDGEMENT

The study would not be completed without the support from the two identified companies; DWAL and DFAL. We are immensely indebted to Mr. Kelzang Phuntsho, Procurement Officer and Mr. Biswas Thapa, Purchase Manager for their cooperation and providing required data and information pertinent to the study. Further, the team owes a heartfelt gratitude to the company for allowing us to study their company which is mostly kept confidential.

We would like to thank our project guide Mr. Karma Drukpa, Asst. Professor and Mrs. Thinley Wangmo, Asst. Lecturer for guiding us in conducting this project, without which our project would not have been successful. We would like to thank Mrs. Namgay Zangmo, Asst. Research Officer for helping us in corresponding with the identified companies and seek approval.

We are also grateful to Jigme Namgyel Engineering College in allowing us to visit the companies, without which we might not be able to collect data and conduct our study.

Finally, we would like to thank all lecturers and friends for providing important advice and guidance

for completing this project.

## REFERENCES

- [1] “Factors Influencing Inventory,” in Material Management, New Delhi, India, Satish Kumar Jain, 2013, pp. 226-231
- [2] J. A. Lopez, M. and J. Masini, “A Classic and Effective Approach to Inventory Management,” International Journal of Industrial Engineering , p. 1, 2013.
- [3] K. K. Kimaiyo, “Role of Inventory Management on Performance of Manufacturing Firms In Kenya - A Case of New Kenya Co-operative Creameries,” European Journal of Business Management, pp. 1-2, 2014.
- [4] P. F. Bingilar, “The Effect of Inventory Cost Management on Profitability,” International Journal of Economics, Commerce and Management , p. 446, 2016.
- [5] T. Wild, Best Practice in Inventory Management, Jordan Hill: Elsevier Science Linacre House, 2002.
- [6] H. Shen, Q. Deng and R. Lao, “A Case Study of Inventory Management in a Manufacturing Company in China,” Nanyang Business Journal , pp. 20-22, 2017.
- [7] S. Shin, K. L. Ennis and W. P. Spurlin, “Effect of Inventory Management,” Economic and Economic Education Research, pp. 98-100, 2015.

## Publicizing on RUB Online Admission

Kezang Wangmo<sup>1</sup>, Yeshe Choden<sup>2</sup>, Jamyang Tashi<sup>3</sup>

Department of Information Technology, Jigme Namgyel Engineering College  
Royal University of Bhutan, Dewathang, Bhutan

Email: kezangwangmo@gmail.com<sup>1</sup>, yeshicoz505@gmail.com<sup>2</sup>, jamyangtashi@jnec.edu.bt<sup>3</sup>

**Abstract - This project is about designing and producing 3D animated video for Online Admission System of Royal University of Bhutan (RUB). Although Online Admission System has been in place for many years, Class XII students aspiring to study in RUB are not fully aware of Online Admission procedures. In spite of the sensitization programs conducted every year for the schools by RUB, challenges are still prevailed. In order to orient and sensitize students on RUB Online Admission System, a 3D animated video was developed to provide a virtual step-by-step guide to Online Admission process. The video tutorial publicizing on RUB Online Admission was developed using Blender 2.79 on Windows OS and Mac OS x. This video will be further published on social networking sites such as YouTube and Facebook and made accessible for information.**

**Keywords — 3D Animation, preproduction, production, post-production, storyboard, background, keyframes, character.**

## 1. INTRODUCTION

The Royal University of Bhutan (RUB), founded on June 2, 2003 by a Royal Decree, is the National University of Bhutan. According to the Royal Charter and the Statutes of the Royal University of Bhutan the overall rationale of the University is to propagate the knowledge and advancement of learning through a balanced, well-regulated and sound tertiary education system for the economic and cultural development of the Kingdom of Bhutan. The University also promotes cultural enrichment, personal development and competency in everyone. The RUB Online Admission is a System through which class XII students can get admitted into the RUB colleges. This project is aimed at developing and producing 3D animated movie that would help in sensitization and awareness on Online Admission procedures. This project will support in creating

effective visual information on the Online Admission to the various program under the constituent colleges of Royal University of Bhutan.

## 2. LITERATURE REVIEW

### 2.1 Introduction

The term Animation defines the movement of characters by a combination of sequence of frames of picture capturing each and every bit of movements involved. The word ‘Animation’ is derived from a Japanese word ‘anime’ which refers to breathe, air and alive. The animation came into existence with the invention of electronic devices, which made it possible for presenting it to the audience. The scope of animation first started in various endeavors and innovations that the field really began to develop in the late-19th century. However, with change in time the various devices are invented to watch the animated films. Frenchman Émile Reynaud created his first animated cartoon in 1892 [1]. After that many 2D and 3D animated films were created out of which the 2D animation was prominent. Today the animation has become one of the popular industries for the purpose of advertisements, education and broadcasting fields.

The animation has helped many of the academic institutions in educating the learners on the subject content. It can be as simple as composition of text, graphics and voice together in enabling the learners to understand the content of the subject. Therefore, animation has become a medium to educate and create awareness among learners in most effective ways.

### 2.2 Animation techniques

Researchers have written many papers on the different techniques to develop the animation video however, while studying in depth, it is broadly categorized into two. The Traditional animation and Modern Animation which is called as Computer animation today. There are also many techniques



to be discussed within traditional animation from which one of them is called Cel Animation. This type of animation is animated through use of papers and Celluloid that is a transparent sheet whereby it requires hand drawn images. A computer animation involves modeling, motion generation and rendering of models using high-end computers.

### 2.3 2D and 3D animation

While discussing on the 2D and 3D animation, the 2D animation is an arrangement of series of frames or pictures in a sequence to create motions. [5] The animator needs to draw the same character in all the movements involved to make the character move. The 3D animation is the process that generates three-dimensional images in a digital environment. Unlike 2D animation, 3D animation does not require series of frames to be drawn. The inventions of Computer Graphic Image (CGI) that can be installed in a computer brought a great view of visual and this contributes to the production of good 3D animation performance [2].

### 2.4 Hybrid animation

The combination of 2D and 3D animation is called hybrid animation. The hybrid animation integrates 2D background with 3D characters or 3D background with 2D characters. One of the books written on hybrid animation also proved that it enhances a scene by choosing to animate the scenic background in 2D while the main character is brought to life with 3D techniques [6].

### 2.5 Animation in Education system and Advertisement

The animation in learning environments can trigger more than one sense at a time and that may be attention getting and attention holding. Having such activities and strategies in all the education premises such as universities and schools to teach the students helps in student learn what is being taught. More over the quality of the education system can be improved drastically thereby promoting the respective universities in terms of quality education [4].

Another major importance of animation is in the area of Advertisement Industries. It has the fourth highest level of employment for animators and demand in the industry is expected to grow [5]. It has become the highlight of digital marketing campaigns because it does not only make promotional online

videos more entertaining but it also communicates effectively. A well-made 3D movie can provide an audience with an unparalleled cinematic experience that stimulates the imagination in a way that is undeniable [3].

## 3. METHODOLOGY

The project was developed considering the procedures and stages found in the animation industry. To this particular project, the project was developed using three stages that comprises of Pre-production, Production and Post-production. Out of the various tools for 3D animation, the tools used in this project is Blender 2.79 for creating, developing and animating the characters. Various other software applications such as Audacity, Adobe Premiere Pro and Adobe After effects were used to enhance the final production.

### 3.1 Preproduction

In this, it is usually an activities that are carried out before the main task of the project. One must get ready with all sort of ideas, tools and other necessary resources to undertake the main task. In this project, the story writing, storyboard, script were some of the key activities taken care under the preproduction stage. In this stage, any works related to 3D, graphics or video were take care as preproduction stage as everything happens before the actual production of the main project.

### 3.2 Production

#### 3.2.1 Character development/design

It is about the box modeling method used in this project. It is based on simple primitive, such as cube, sphere, or cylinder. The project also used Poly-to-Poly Modeling that allows drawing a shape one polygon at a time. In both the modeling, subdivision surface modifier was applied to smooth the geometry.



Figure 1: Character model

### 3.2.2 Painting character

This project used the Material Editor located in the Properties Editor panel to apply color to the character. Solid color was applied to skin, hair and clothing. The texture for the 3D model's surface was further enhanced using materials, such as how reflective or shiny they are and whether they are rough or smooth.

### 3.2.3 Character rigging

Fig. 3. In this, it display the lists of bones that make up a rig to develop the character. In this project the various bones that were used were bone, deform bone, control bone and constraints. Few bones were added for the head, neck, arms, hands, torso, backbone, legs and foot. The deform bone was used to move the mesh and it is usually hidden and moved by the control bones. The control bone was exclusively used to pose and control the character.



Figure 2: Character rigging

### 3.2.4 Defining weights

The legs, arms, head and torso requires movement and deformation thereby applying Weights Paint. The weights paint are described in four colors; red, orange, yellow and green. The arms leg and foot were assigned red weight paints, whereas the torso and backbone, which did not require distinct movements, were applied with orange weight paints.

### 3.2.5 Background development/design

The background and the fields were developed using particles, shadow, shading and sun lamp lighting features. Blender provides options to choose the color for the background from the World Tab in the Properties editor.

### 3.2.6 Animating the character

It is the process of making the movement of character along time. It is important to understand the principles of motion, such as action and reaction and also about how weight affects the character movement. The main component of animating the character is inserting of the key frames.

### 3.3 Postproduction



Figure 3: Animating the Character

In this stage, it is the activity where the final touch up on the works carried out in the production

stage such as calculating the time frames, synchronizing with the sound, testing the graphics and videos in various platform etc. In this project, as a postproduction activity, Sun lamp was used as the source of light to the model since this type of lighting provided equal lighting to every object. The camera position for this animation was kept static so that it takes less time while rendering the final works. In this project, the postproduction activities also included merging videos, adding sound effects and cinematic effects to the final rendered videos. Adobe Premier was used as the main tool to merge all other short clips. The movement, motion, timeframe, synchronization were some of task carried out in the accomplishing the final result.

## 4. RESULT

The figure 4 is the final product of the developed model that was developed using the Blender 2.79. These are two characters in the animated video.

Fig. 5. The two characters greeting each other with the background.

The complete product of the animation is readily available in the MPEG format that is of





Figure 4: Developed character model



Figure 5: Developed model with background.

4 minutes video that captures the complete story on how to do the Online Admission to the various program under the constituent colleges of the Royal University of Bhutan.

## 5. CONCLUSION

The designed based project has achieved in creating 3D animation in a simple version. The outcome of this project will facilitate especially Class XII students in guiding the Online Admission procedures of RUB at ease.

## 6. RECOMMENDATION

Similar kind of project can be carried out using other 2D and 3D software. In the animation industry, Adobe Flash Player, Maya and 3D Max are some of the commercial software that are designed to develop the 2D and 3D animation. This particular project can be improved using the other open source software that are readily available in the internet by composing the 3D character with the additional 2D scene as the background. Similarly, re-recording the background sound and composing to the video would make more interesting. The project was focused on hands on learning on how to use blender to develop than 3D

animation than the final product. Therefore, if the project is product oriented, then it can be improved by importing readily made characters, composing with other 2D objects and make the final product that would be more interesting and convincing of the story to the viewers.

## 7. ACKNOWLEDGEMENT

We would like to extend heartfelt gratitude to Jigme Namgyel Engineering College, Royal University of Bhutan for having the project as a part of the curriculum to experience hands-on learning. The project would not be successful without the support from the Head of the Department, Mr. Ugyen Namgyel, project guide Mr. Jamyang Tashi for their continuous support and guidance during the project time. We would also like to take this opportunity to thank project coordinator Ms. Sonam Wangmo for coordinating and timely reminder, Mr. Namgay Dorji and Ms. Thinley Wangmo for taking their precious time and effort in going through the report and providing the feedback to be incorporated. Lastly our sincere thanks to Mr. Jigme Tenzin, Head, Department of Civil Engineering, for providing us to use Survey lab for rendering our works. We would also like to thanks all the module tutor and friends for their feedback and all kind of support provided during the project time.

## REFERENCES

- [1] Animation. (2010). Infobase Publishing.
- [2] Axedevil. (2015). Project report 3D animation. JSS Academy of Technical Education India, Department of Computer Science.
- [3] Cullen, T. (2010). Digital Moviemaking.
- [4] Reeves, T. (1998). The Impact of Media and Technology in Schools:A research report.
- [5] Staff. (2016, August 11). Animation in advertising: how important is it? Retrieved from <https://www.animationcareerreview.com/articles/animation-advertising-how-important-it>
- [6] Tina, O. H. (2010). Hybrid animation: integrating 2D and 3D Assets. Focal Press.